

ETRUSCO
DESIGN ETTORE SOTTsass

Istruzioni di montaggio ed utilizzo
Assembling and use instruction

GLAS
ITALIA

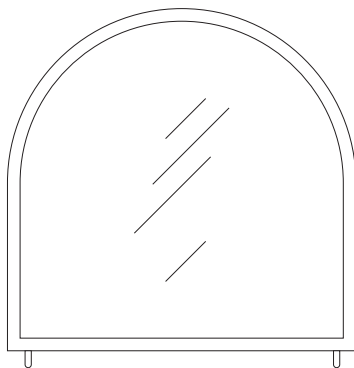
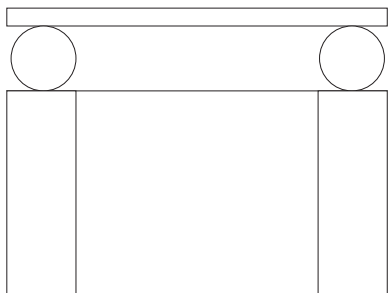

Accessori / Tools



step 1

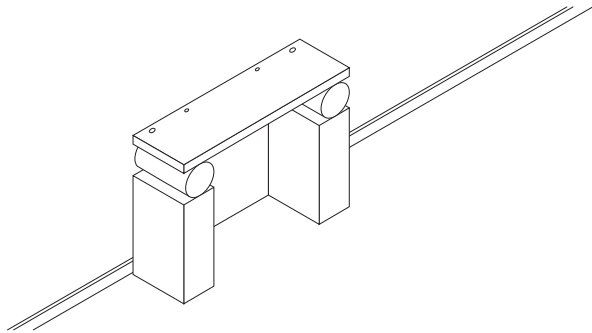

step 2

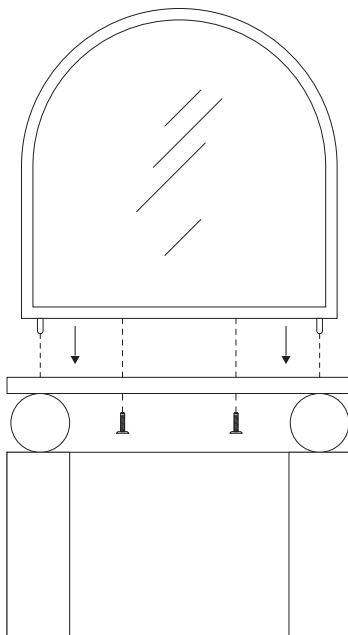

ITALIANO

step 1. Posizionare la base a ridosso della parete.

step 2. Fissare lo specchio alla base utilizzando le viti in dotazione.

ENGLISH

step 1. Place the base close to the wall

step 2. Fix the mirror to the base using the supplied screws.

FRANÇAIS

step 1. Positionner la base tout près de la paroi.

step 2. Fixer le miroir à la base en utilisant les vis fournies.

DEUTSCH

step 1. Stellen Sie das Untergestell in unmittelbarer Nähe von der Wand auf.

step 2. Befestigen Sie den Spiegel an dem Untergestell mit den mitgelieferten Schrauben.

ESPAÑOL

step 1. Posicionar la base contra la pared.

step 2. Fijar el espejo a la base utilizando los tornillos incluidos.



ATTENZIONE

Nel maneggiare il cristallo, evitare urti e non appoggiarlo su superfici che possano causare scheggiature o graffi.

ATTENTION

When assembling any glass furniture composition, be sure to rest the glass on soft surface to avoid scratches, chips or abrasions.

ATTENTION

Manier le cristal en évitant les chocs et ne pas l'appuyer sur des surfaces pouvant causer ébrouures ou griffures.

ACHTUNG

Um Schäden an dem Glas zu vermeiden, die Glasplatte nicht auf Oberflächen ablegen, die diese zersplittern oder verkratzen könnten.

ATENCIÓN

Al desplazar el cristal, evitar apoyarlo sobre superficies que puedan crear marcas o rayas.

