



**Sistema scorrevole per porta a scomparsa - Binario 1 via
Pocket door sliding system - 1 way rail**

Informazioni pre-montaggio / Pre-installation informations	pag.	1.102
Installazione trave per cartongesso / Plasterboard beam installation	pag.	1.104
Montaggio porta a scomparsa - anta singola / Pocket door installation - single door	pag.	1.112
Montaggio porta a scomparsa - anta doppia / Pocket door installation - double door	pag.	1.130



**ATTENZIONE: Prima di proseguire con il montaggio, leggere attentamente tutto il fascicolo delle istruzioni. /
WARNING: Before proceeding with the installation, read carefully all the installation manual.**

ALADIN

Binario a soffitto nel cartongesso a 1 via / 1 way rail into plasterboard ceiling

Varianti di montaggio / Installation options

ALADIN

codici composizioni / compositions codes

GSC11100 / GSC11001 / GSC11002 / GSC11003

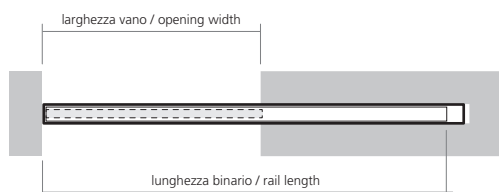

- * Lunghezza binario 20mm in meno rispetto alla trave
- * Rail length 20mm less than the beam

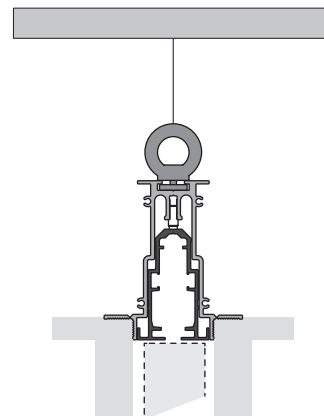

versione appendinata (A)
hanger fixings (A)

codici composizioni / compositions codes

GSC21000

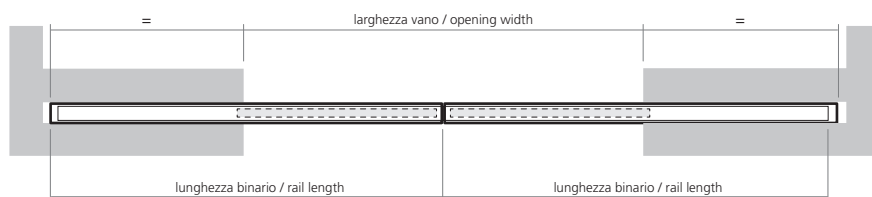

- * Lunghezza binario 20mm in meno rispetto alla trave
- * Rail length 20mm less than the beam

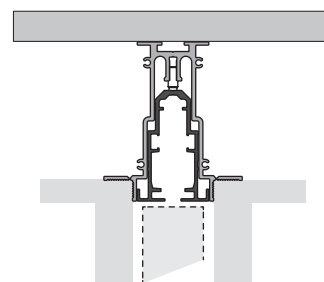

versione a soffitto (B)
ceiling fixings (B)

SHERAZADE

Binario a soffitto nel cartongesso a 1 via / 1 way rail into plasterboard ceiling

Varianti di montaggio / Installation options

SHERAZADE

codici composizioni / compositions codes

GSC11100 / GSC11001 / GSC11002 / GSC11003

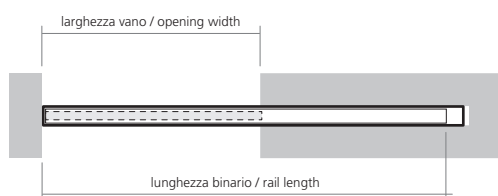

- * Lunghezza binario 20mm in meno rispetto alla trave
- * Rail length 20mm less than the beam

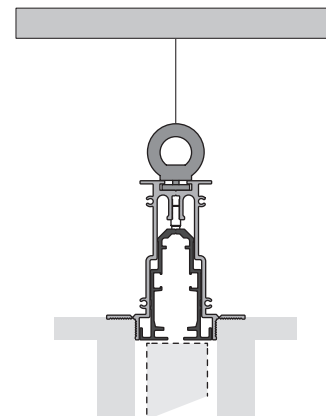

versione appendinata (A)
hanger fixings (A)

codici composizioni / compositions codes

GSC21000

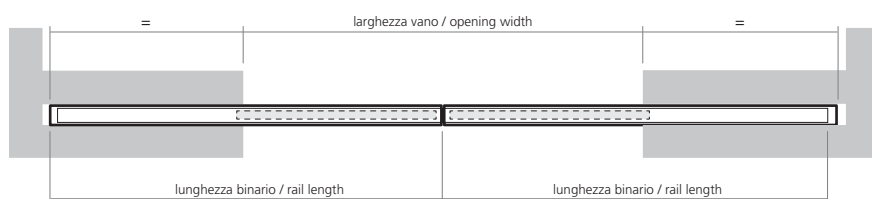

- * Lunghezza binario 20mm in meno rispetto alla trave
- * Rail length 20mm less than the beam

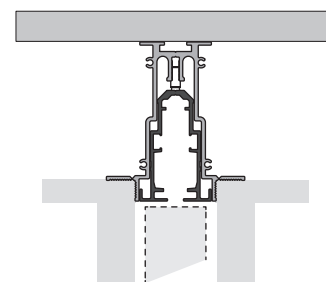

versione a soffitto (B)
ceiling fixings (B)

Informazioni pre-montaggio versione B / Version B pre-installation information

Posizione della trave rispetto al vano. Per codici: / Beam position in consideration of the opening. For codes: GSC21000

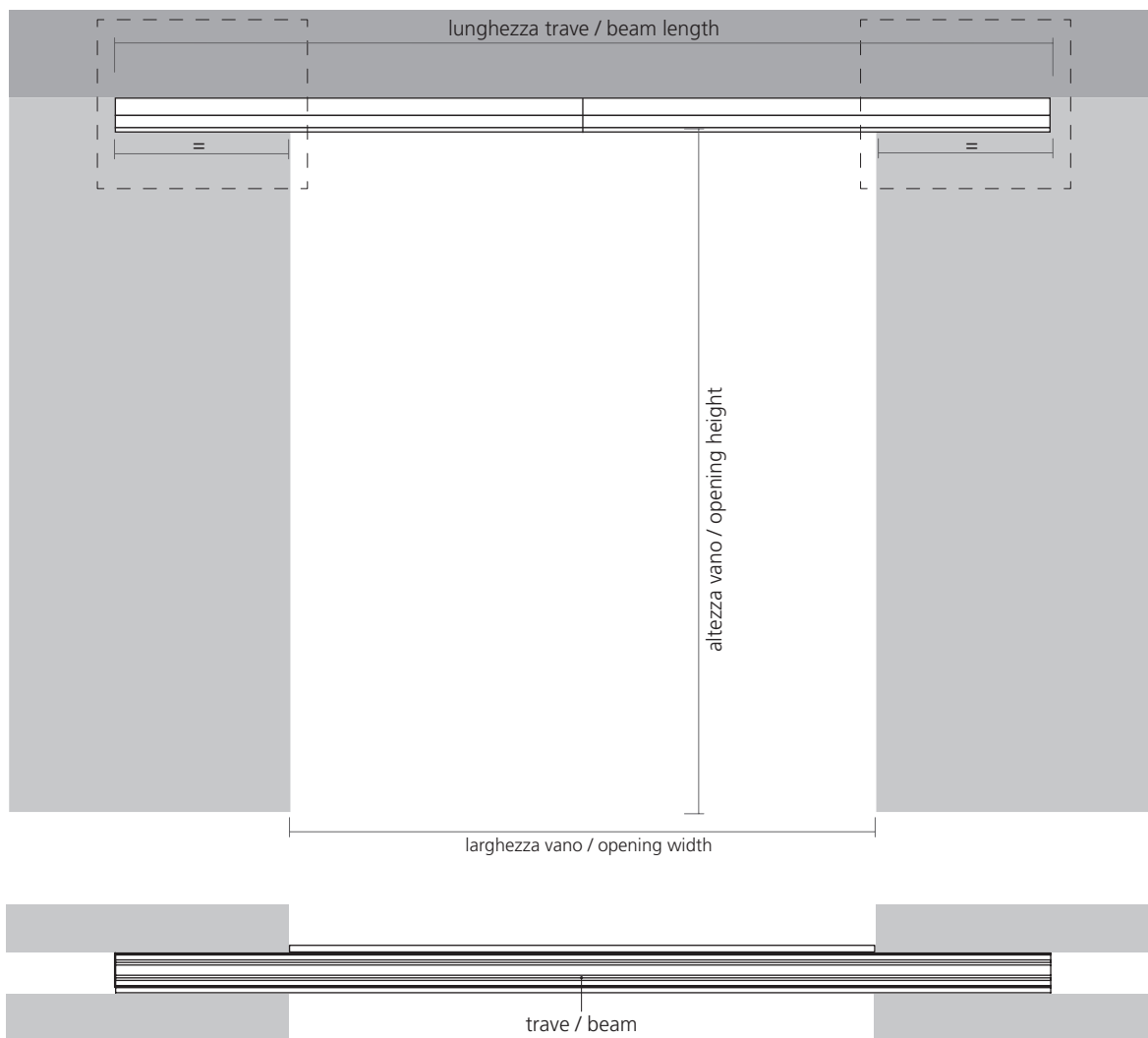

- * Chiudere la parete dopo aver posizionato la trave
- * Finish the wall after placing the beam

ALADIN / SHERAZADE

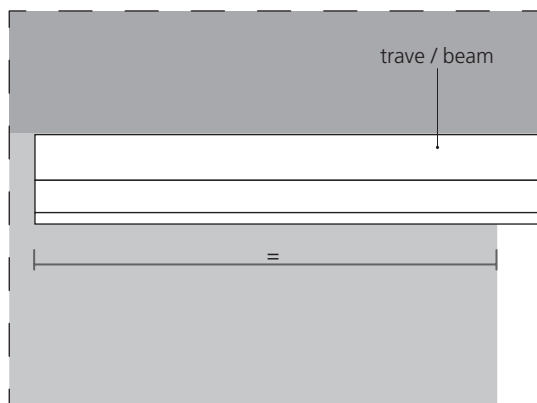

ALADIN / SHERAZADE

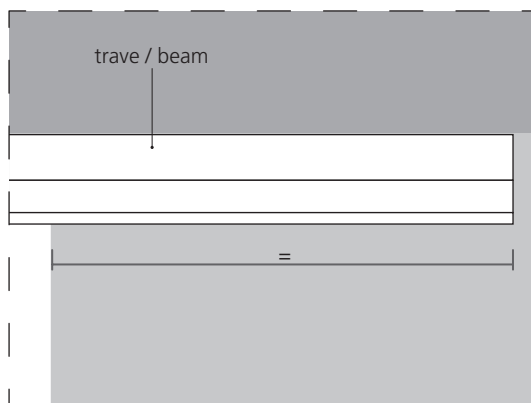

Informazioni pre-montaggio versione D / Version D pre-installation information

Posizione della trave rispetto al vano. Per codici: / Beam position in consideration of the opening. For codes:
GSC11100 / GSC11001 / GSC11002 / GSC11003

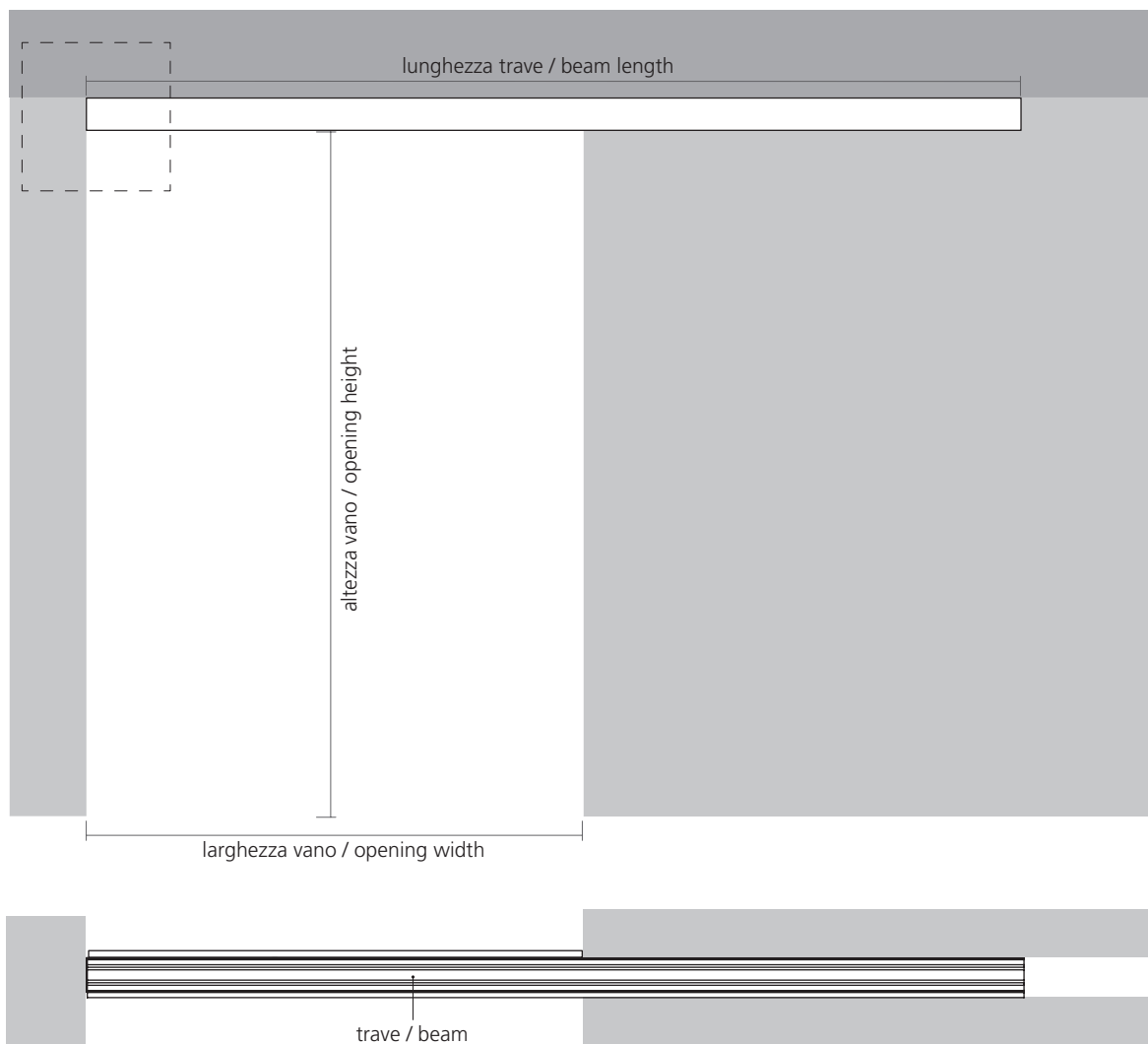

- * Chiudere la parete dopo aver posizionato la trave
- * Finish the wall after placing the beam

ALADIN / SHERAZADE

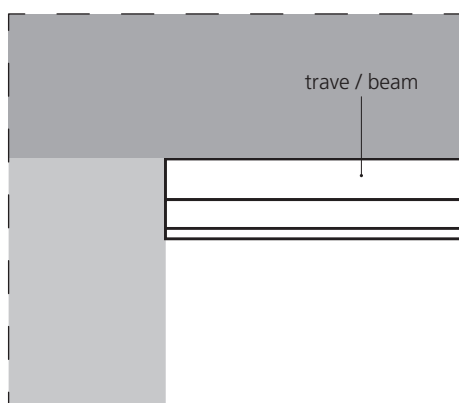

Informazioni pre-montaggio box versione A / Pre-installation information box version A

1. Posizionare la trave per cartongesso nella posizione stabilita.
1. Place the beam for plasterboard ceiling in the established position

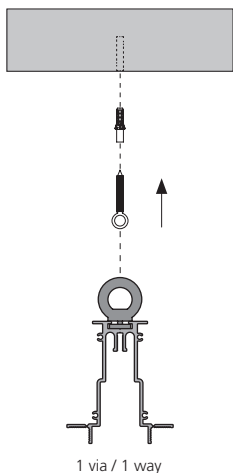

2. Prima di fissare il cartongesso, verificare che la misura dal pavimento al controsoffitto sia quella comunicata nell'ordine.
2. Before fixing the plasterboard, check that the distance between floor and false ceiling is the one specified on the purchase order.

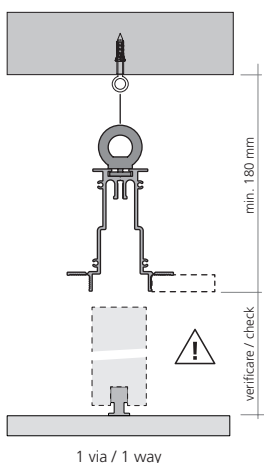

3. Posare e fissare il cartongesso.
3. Lay and fix the plasterboard ceiling.

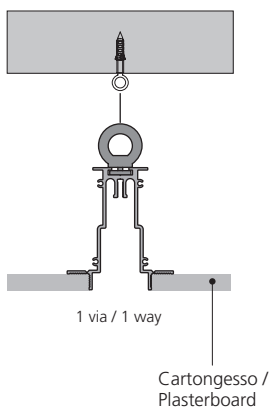

Informazioni pre-montaggio box versione A / Pre-installation information box version A

1. Inserire la piastrina nella sede sulla trave.

1. Insert the plate into the slot on the beam

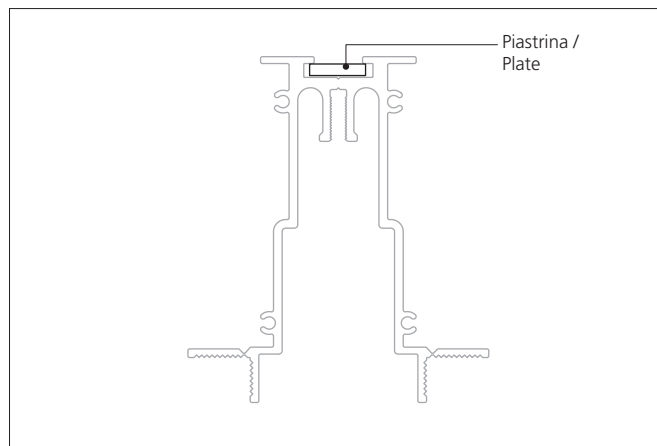
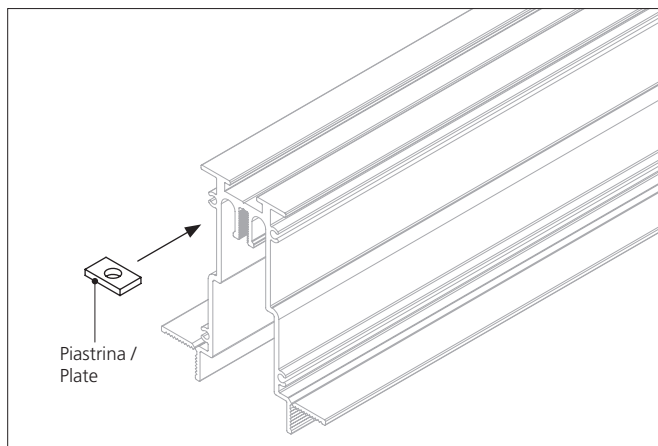

2. Avvitare l'anello nella piastrina.

2. Screw the fixing ring into the plate.

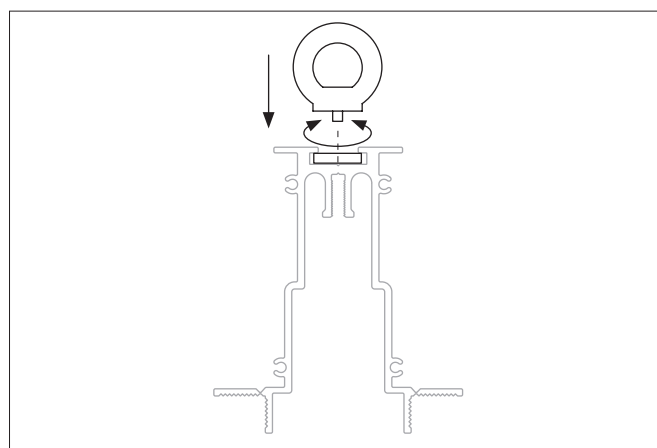
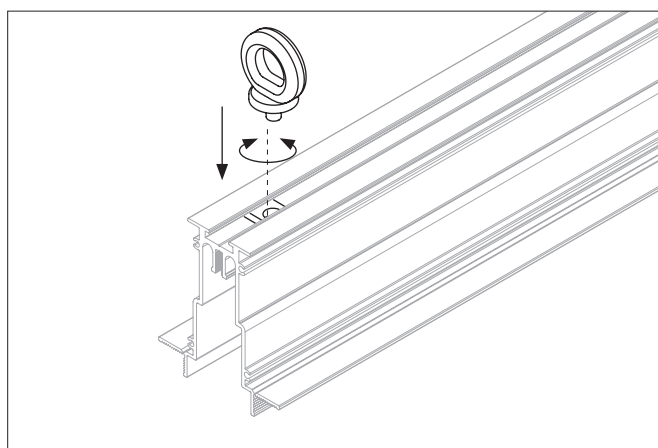

3. Inserire un numero di anelli adeguato alla lunghezza della trave.

3. insert the correct number of rings into the beam according to its length.

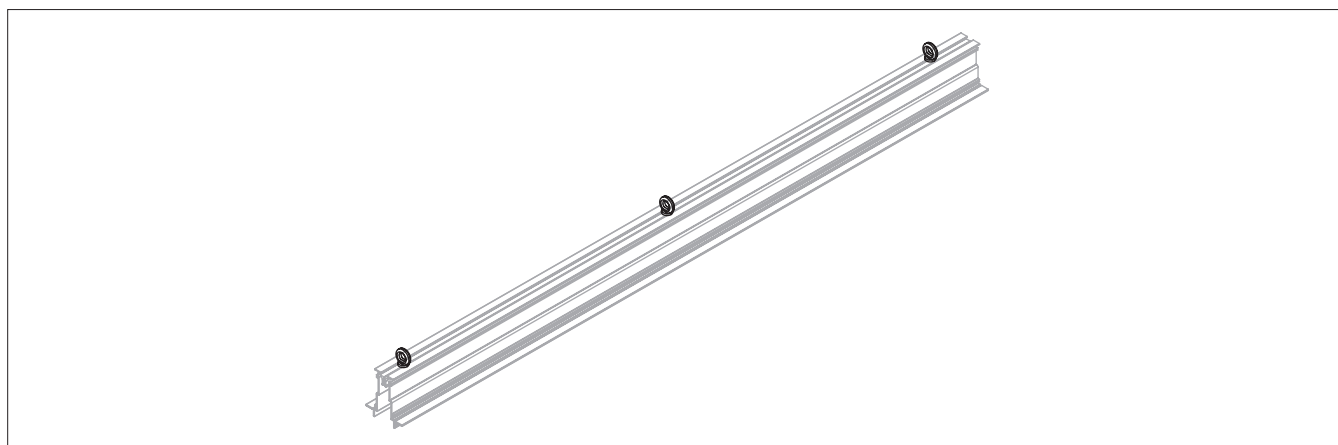

Informazioni pre-montaggio box / Pre-installation information box

In particolari casi di montaggio, eliminare aletta per fissaggio cartongesso per avvicinare la trave alla parete.
 In special installation cases, cut the bracket that usually hold the plasterboard in order to bring the beam closer to the wall.

Esempio configurazione - Trave 1 via per soffitto cartongesso /

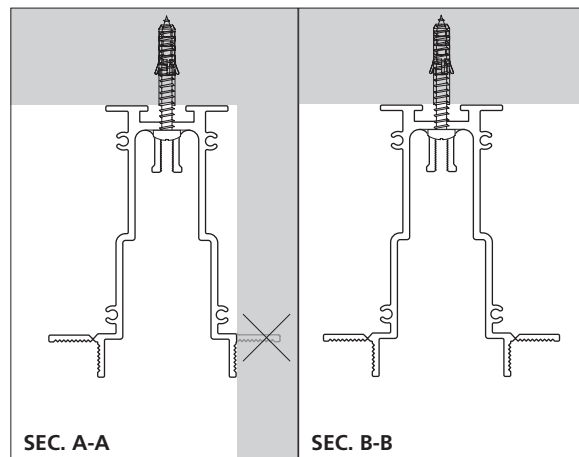
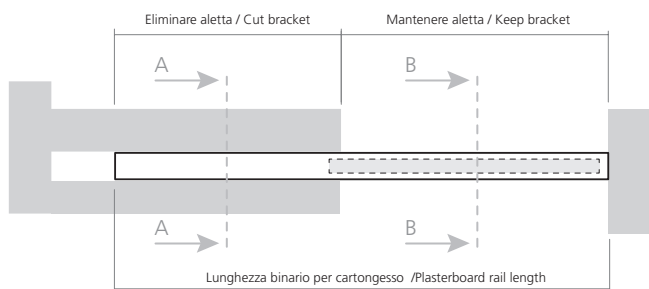

ATTENZIONE: Eliminare aletta per cartongesso nella tratta in corrispondenza della parete.
NOTE: cut bracket, that usually hold the plaster board, to get close to the wall.

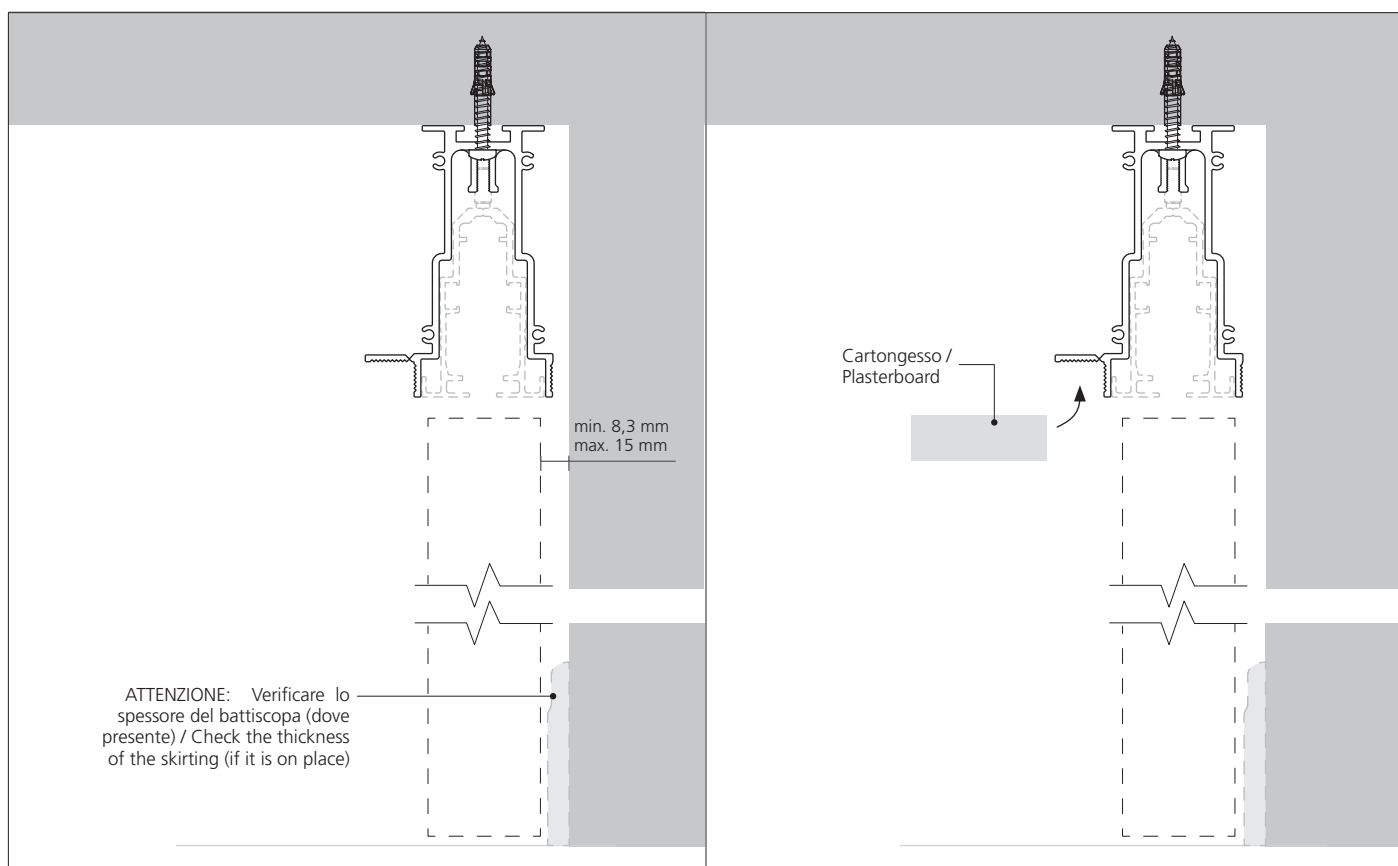

ATTENZIONE: Prima di posare il cartongesso, regolare la distanza tra trave e parete per consentire una corretta apertura dell'anta.
ATTENTION: before installing the plasterboard, adjust the distance between the beam and the wall system to allow a correct opening of the door.

Informazioni pre-montaggio box versione B / Pre-installation information box version B

1. Posizionare la trave per cartongesso nella posizione stabilita.
1. Place the beam for plasterboard ceiling in the established position.

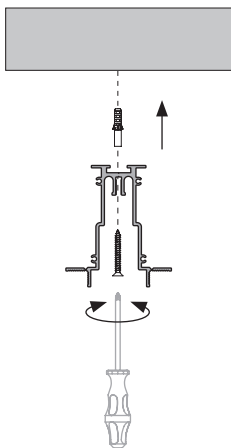

2. Prima di fissare il cartongesso, verificare che la misura dal pavimento al controsoffitto sia quella comunicata nell'ordine.
2. Before fixing the plasterboard, check that the distance between floor and false ceiling is the one specified on the purchase order.

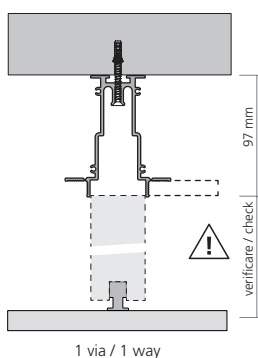

3. Posare e fissare il cartongesso.
3. Lay and fix the plasterboard ceiling.

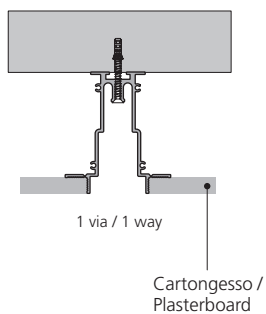

Informazioni sul montaggio del cartongesso / Plasterboard installation information

1. Appoggiare la lastra di cartongesso alla trave.

1. Lay the plasterboard slab against the beam.

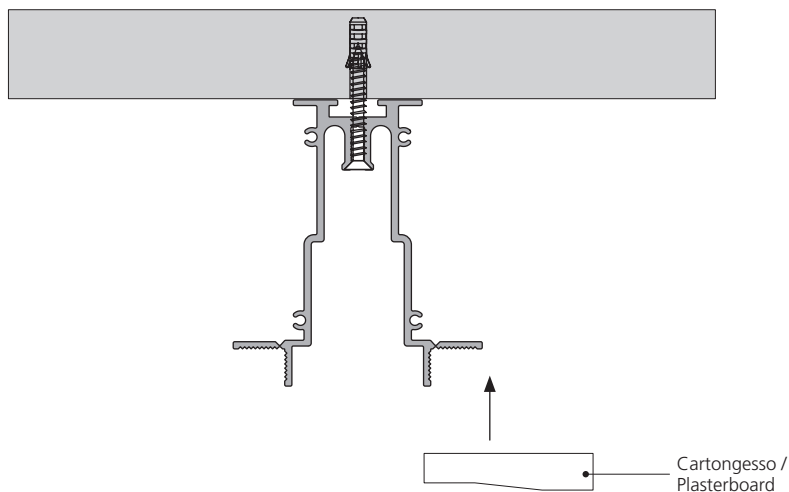

2. Avvitare le lastre di cartongesso alla trave.

2. Screw the plasterboard slabs to the beam.

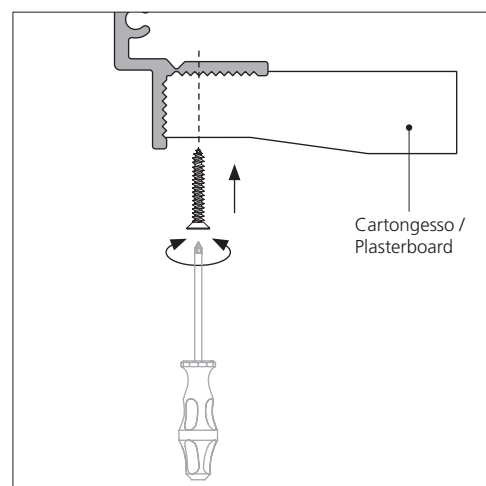
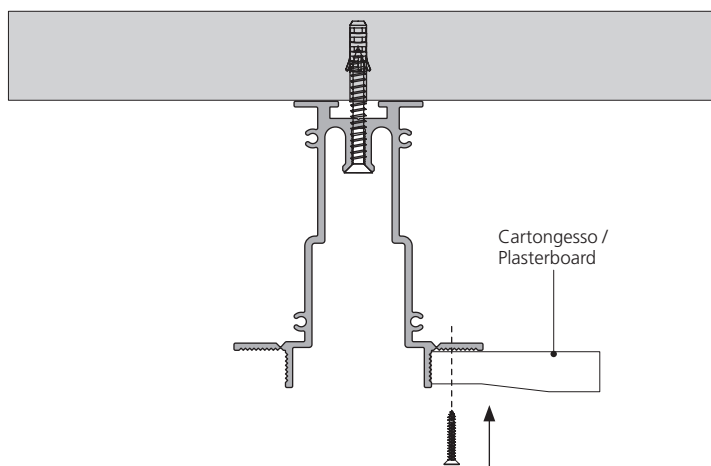

3. Stuccare e rasare il cartongesso.

3. Fill and shave the plasterboard.

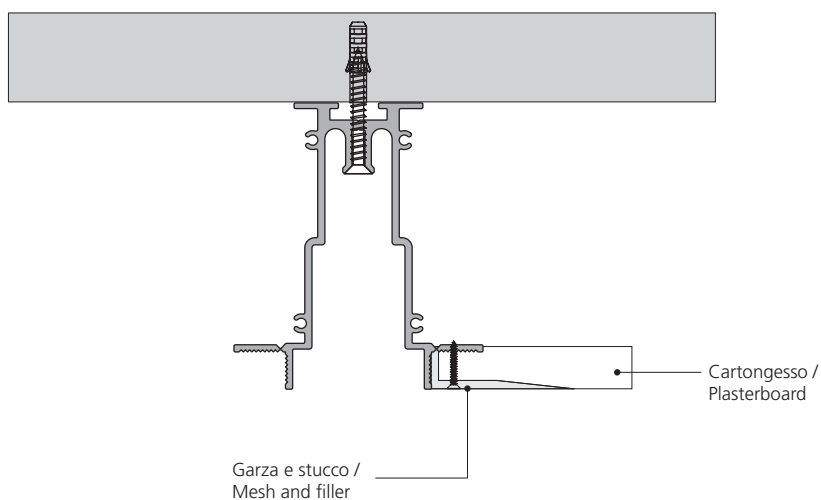

Informazioni pre-montaggio del binario / Pre-installation information of the rail



ATTENZIONE: il binario, per essere montato, deve essere più corto della misura della diagonale del vano.
ATTENTION: the rail, to be installed, must be shorter than the dimension of the diagonal of the opening.

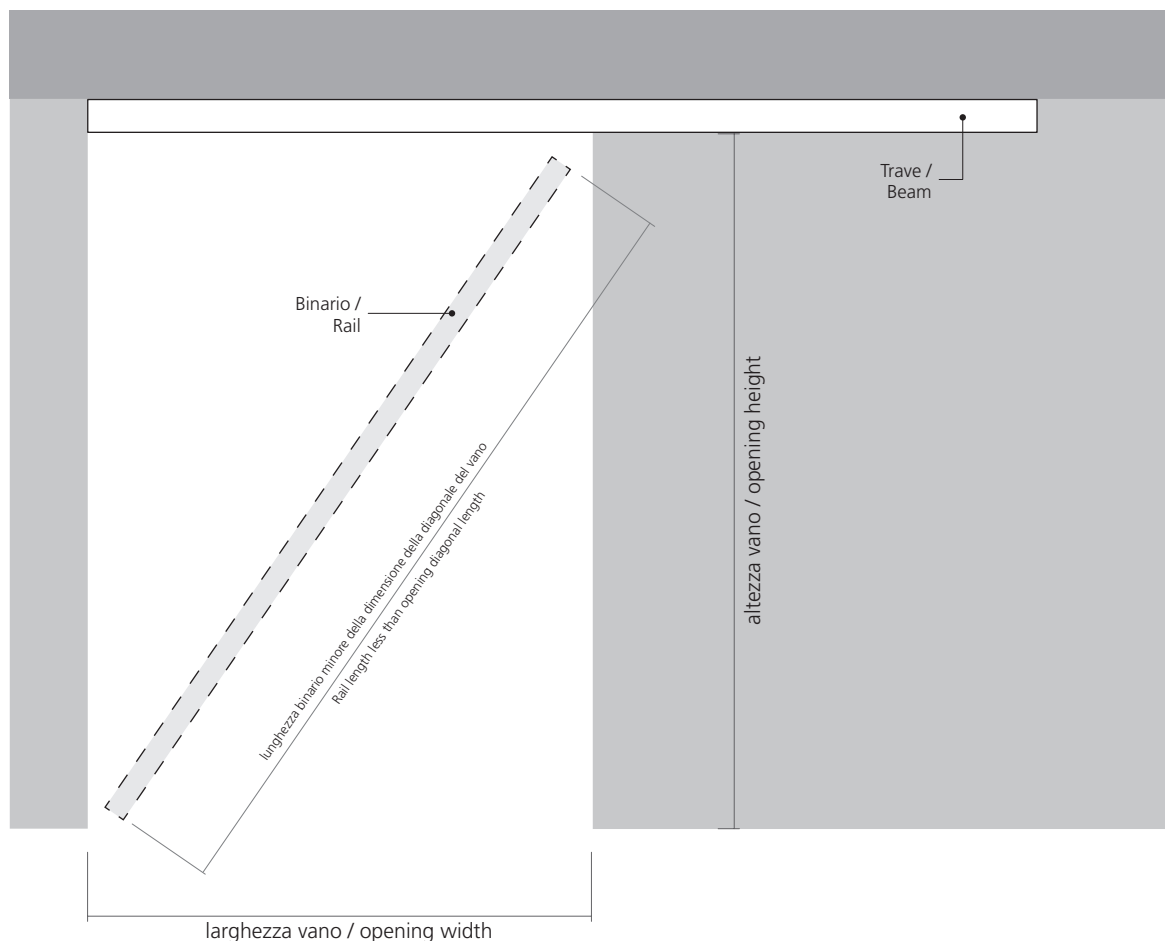

ATTENZIONE: Prima di proseguire con il montaggio, leggere attentamente tutto il fascicolo delle istruzioni. /
ATTENTION: Before proceeding with the installation, read carefully all the installation manual.



Sistema scorrevole per porta a scomparsa | Anta singola | Montaggio
Pocket door sliding system | Single door | Installation

Versione a soffitto / Ceiling fixings

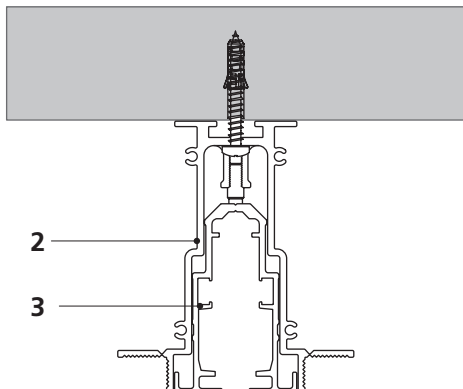

Versione appendinata / Hanger fixings

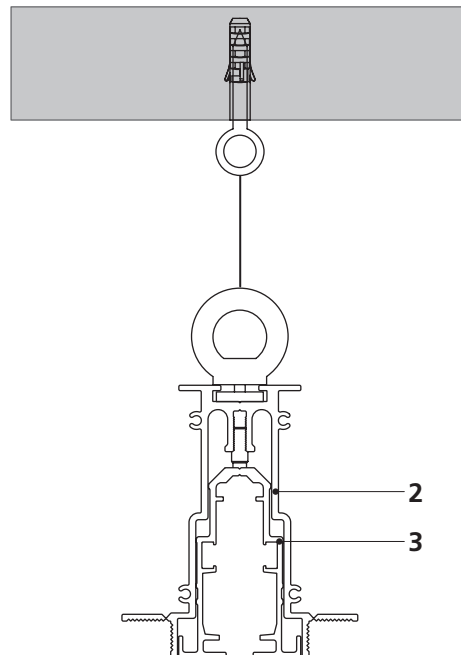

Versione a soffitto / Ceiling fixings

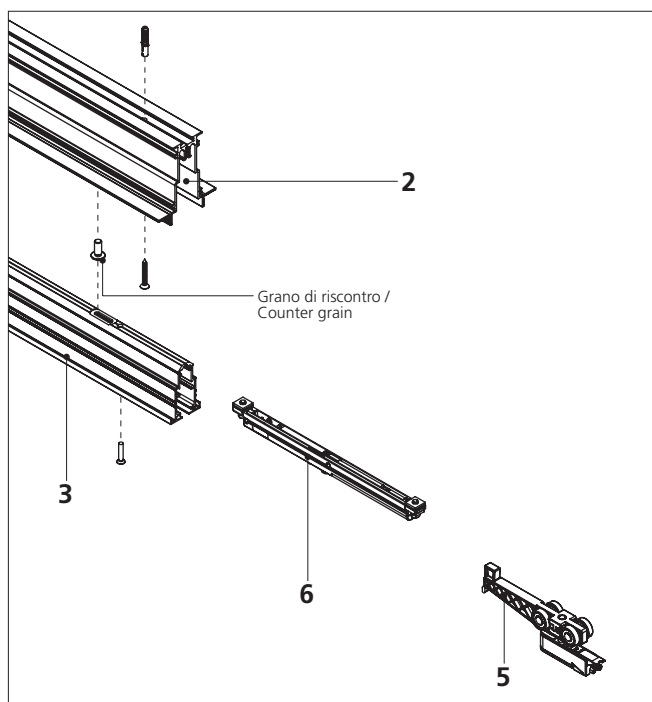

Versione appendinata / Hanger fixings

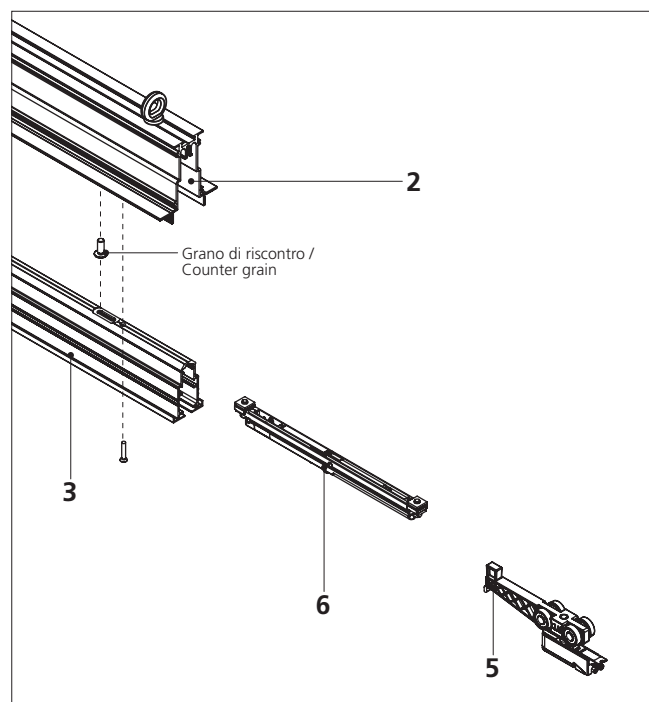

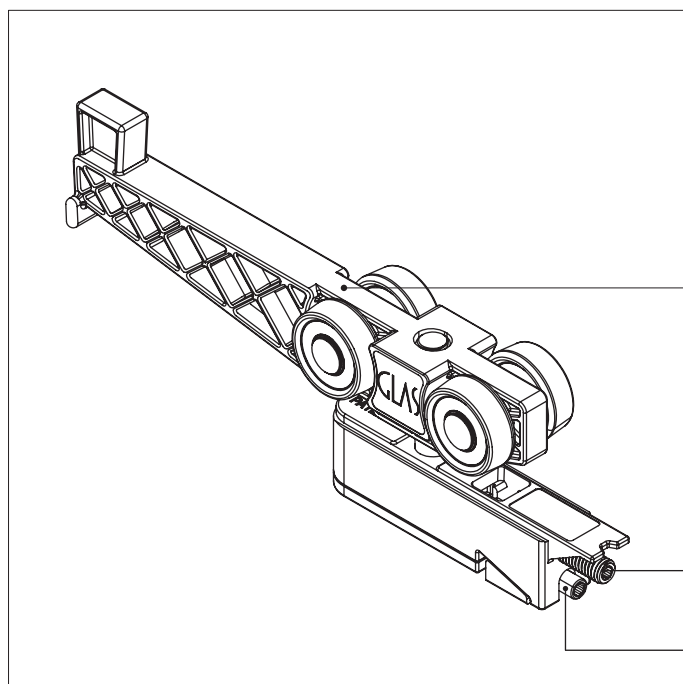

- 2. Trave / Beam
- 3. Binario / Rail
- 4. Staffa / Bracket
- 5. Carrello / Carriage
- 6. Rallentatore / Slow motion device

5

Vite di regolazione /
Adjustment screw

Vite di fissaggio /
Fixing screw



6

Simbologia e strumenti di montaggio / Symbology and assembly tools



Fare attenzione/
Pay attention



Avvicinare - togliere/
Bring closer - Remove



In squadra/
At right angle



Allineare/
Align



Avvitare-regolare/
Screw-adjust



Inserisci/
Insert



Quota/
Level

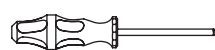

Cacciavite a croce/
Crosshead screwdriver



Chiave a brugola/
Allen key



Chiave per regolazione/
Adjustment wrench

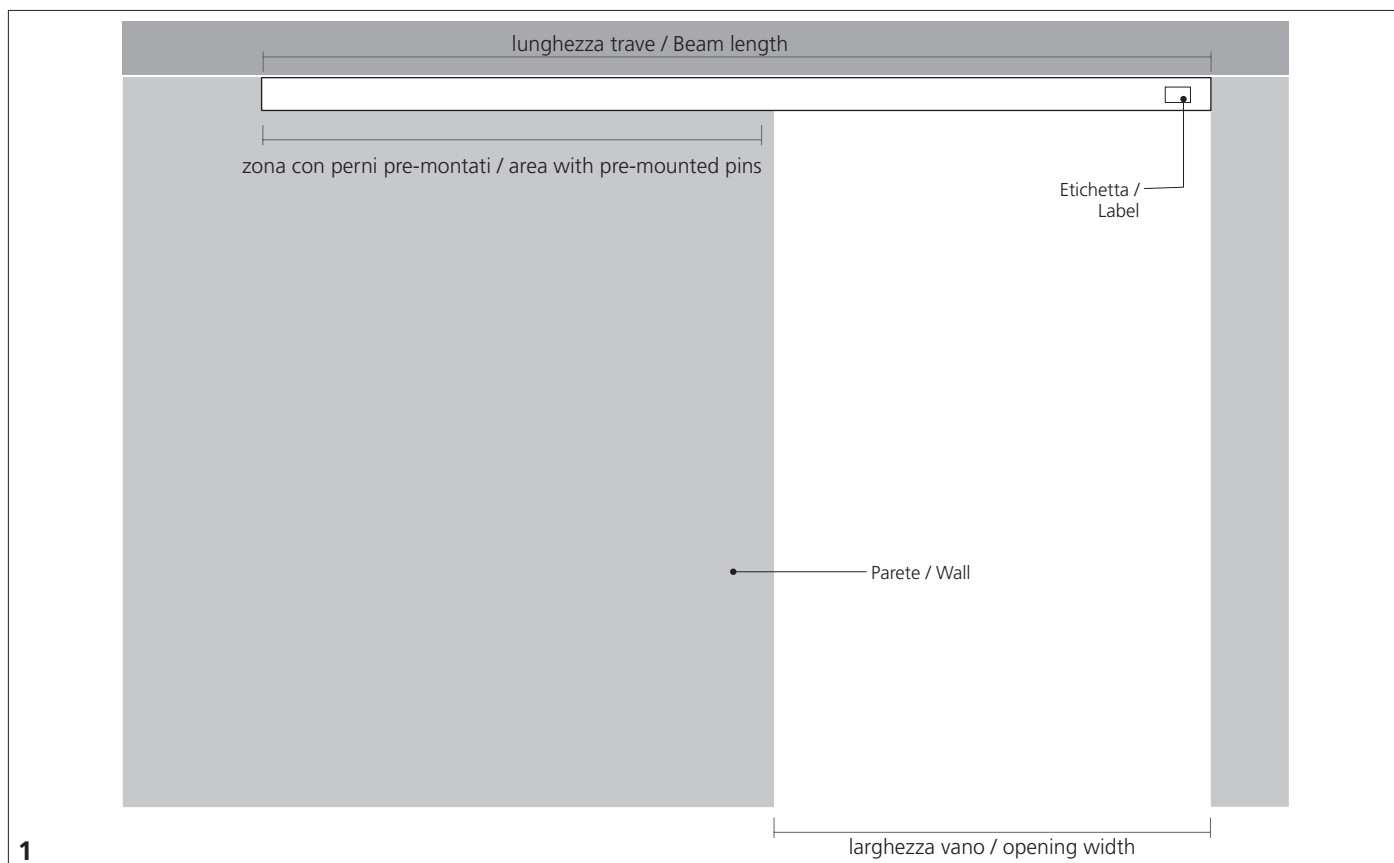

1. Fissare la trave, facendo attenzione al verso di montaggio: l'etichetta indica il lato da lasciare nel passaggio libero.
 1. Fix the beam, paying attention to the sliding direction: the label indicates the rail side to be installed in the opening passage.

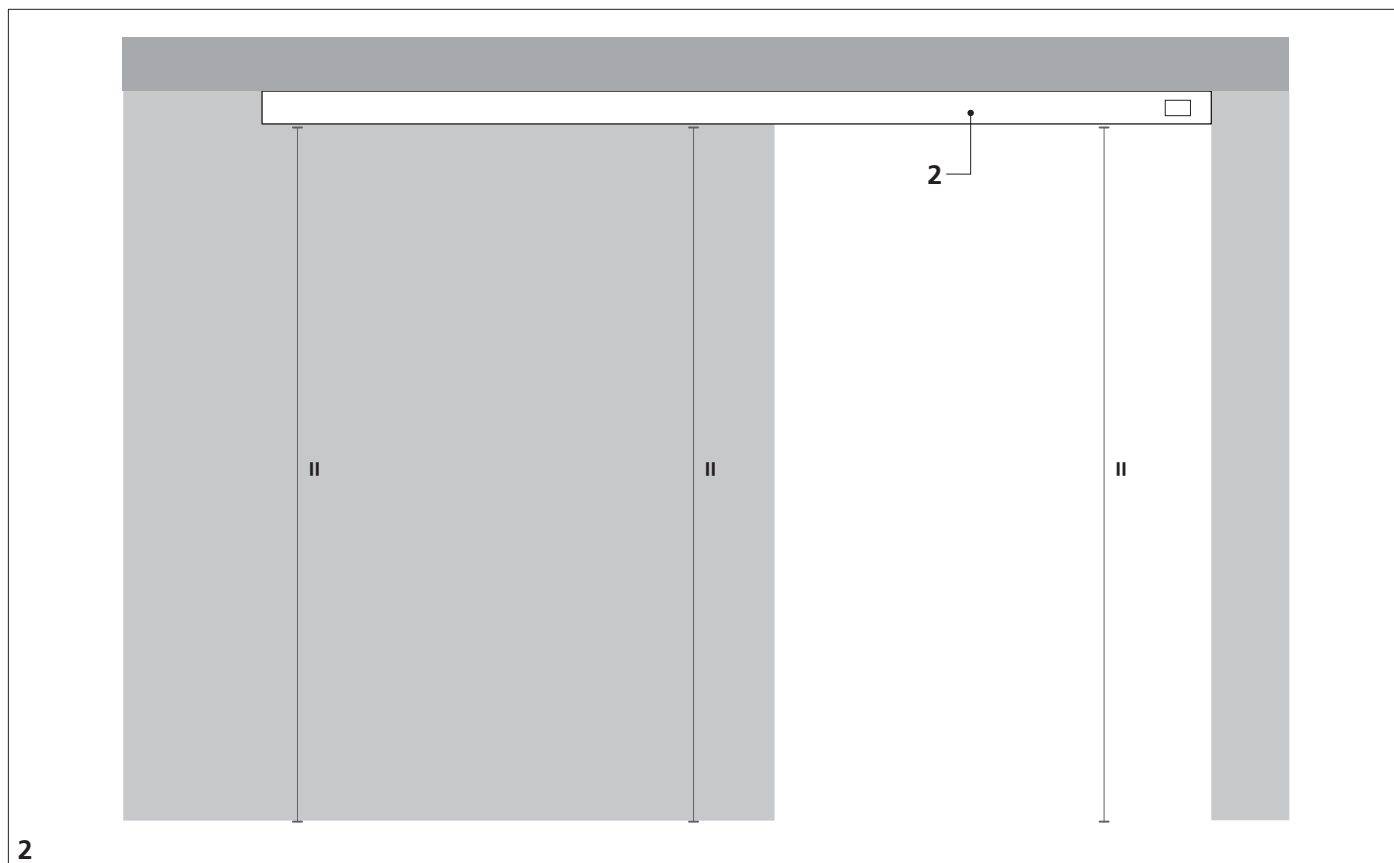

2. Verificare che la trave venga montata senza che ci sia una flessione. La trave deve essere in bolla.
 2. Check the beam is installed without a bending. The beam must be levelled.

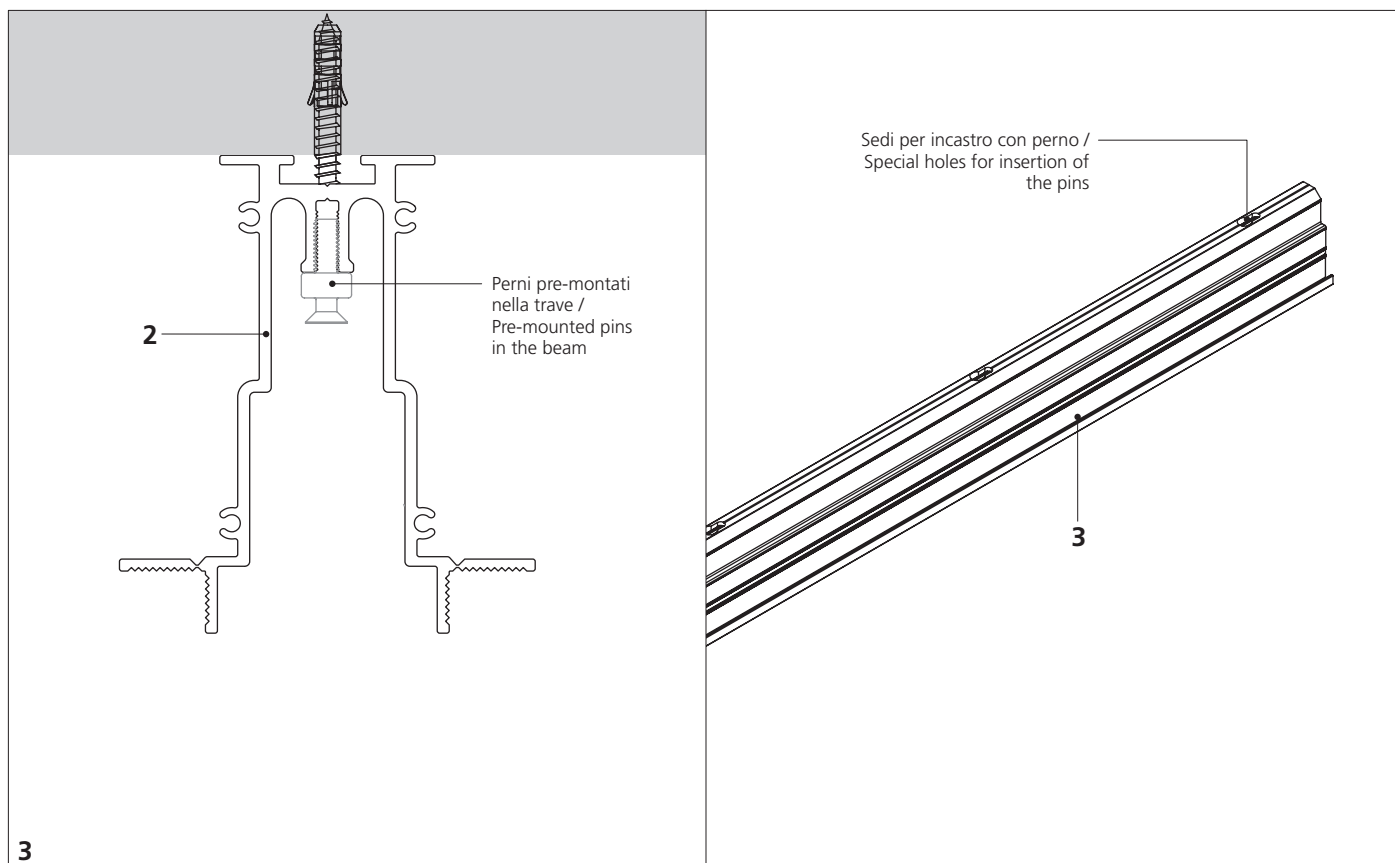

3. Il binario ha delle apposite sedi adatte all'incastro con il perno nella trave.

3. The rail is fitted with special holes suitable for the insertion of the pins already installed in the beam.

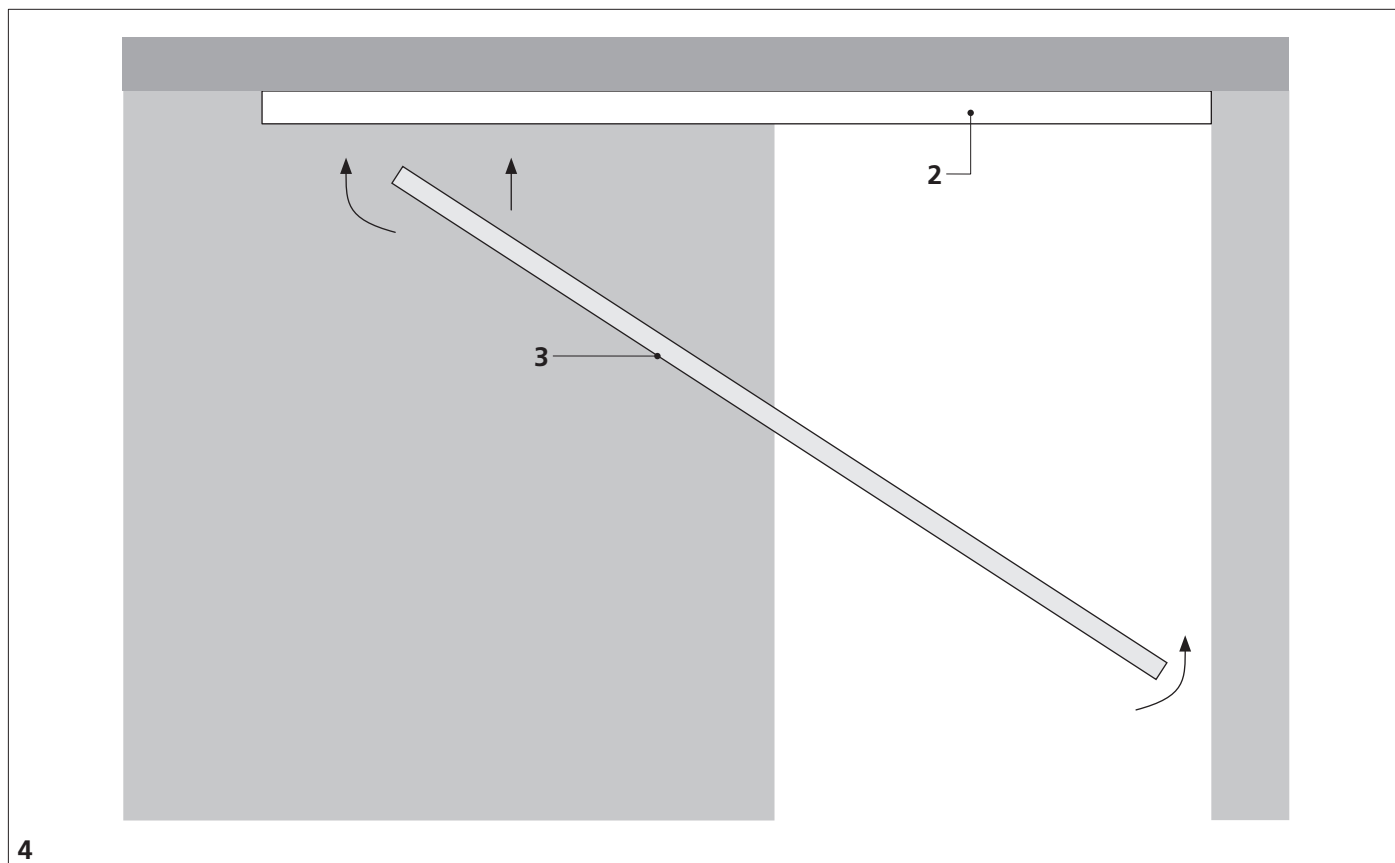

4. Inclinare il binario ed inserirlo nella trave, facendo corrispondere i perni con le sedi poste sul binario stesso.

4. Incline the rail and put it into the beam, making the pins coinciding with the holes on the track.

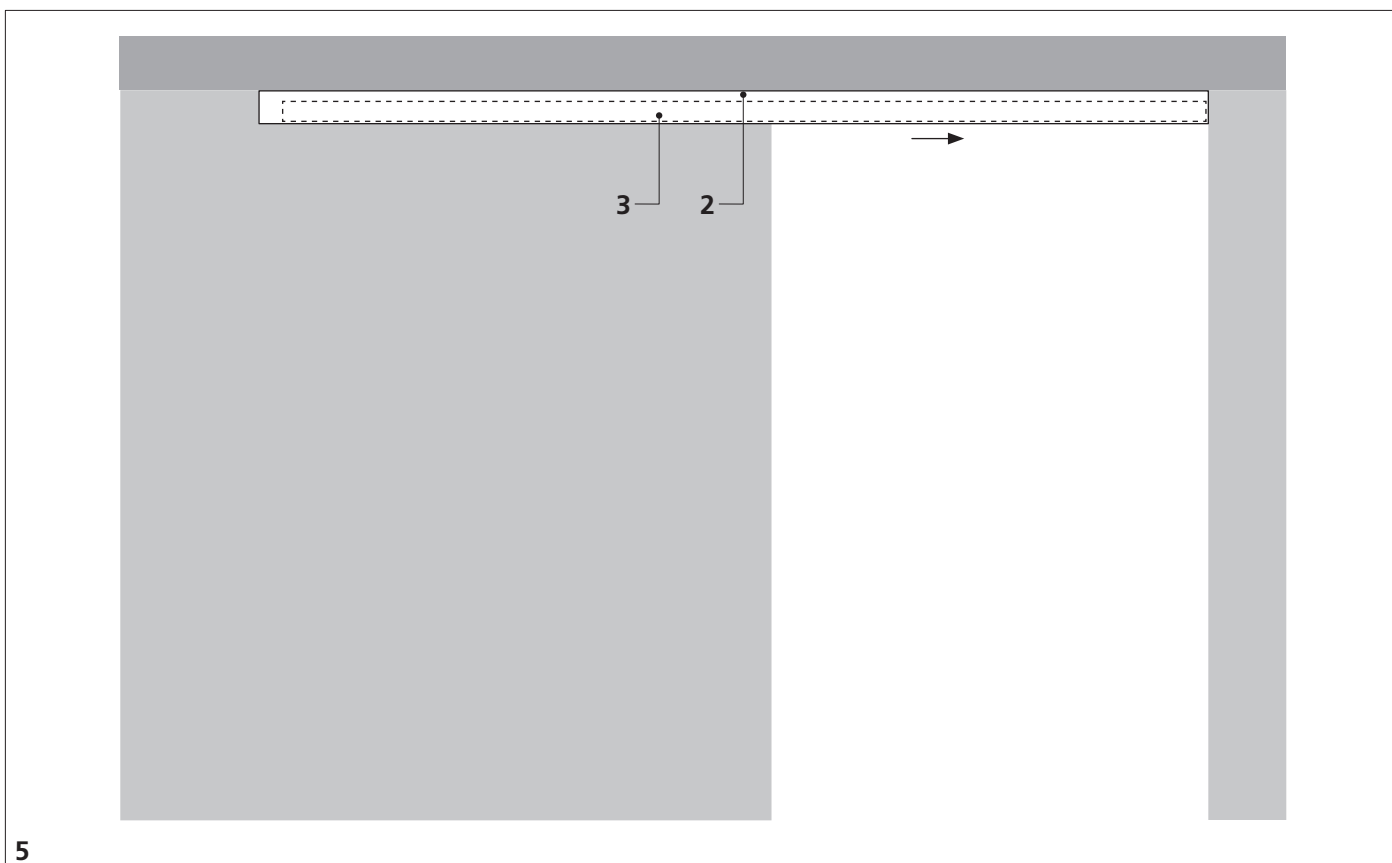

5. Tirare il binario verso la zona frontale della trave per bloccarlo in posizione.
5. Pull the rail towards the front area of the beam to lock it into position.

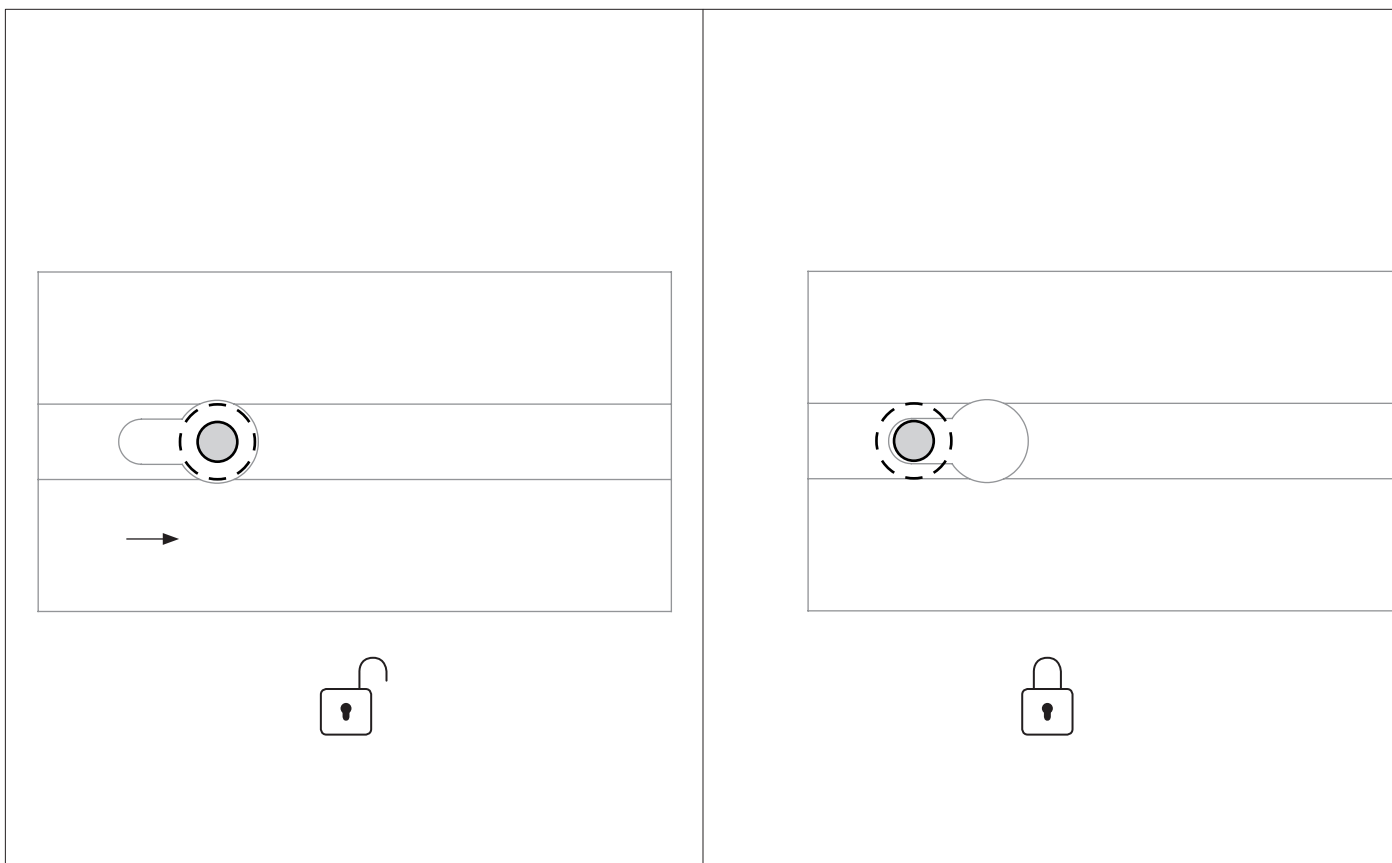

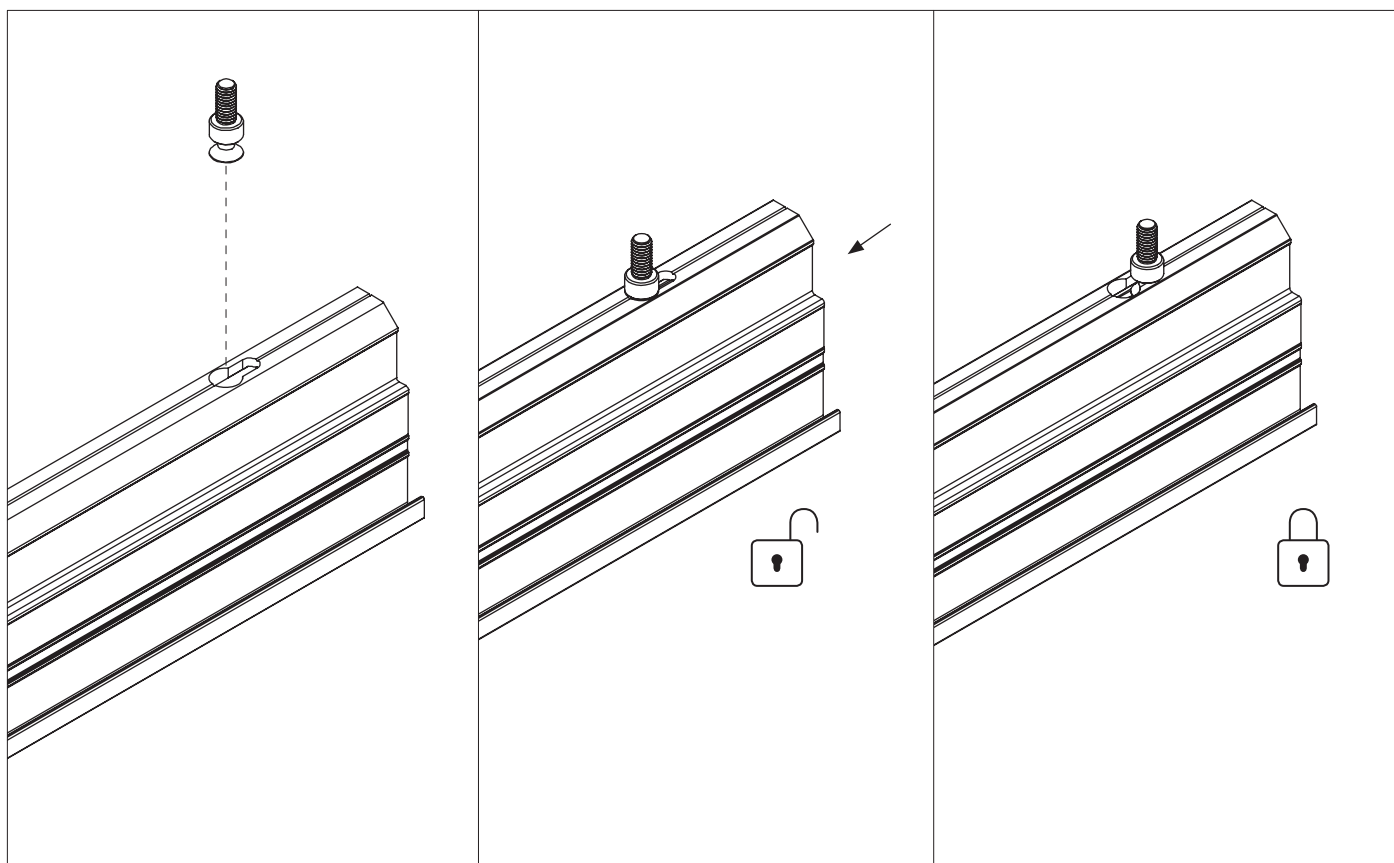

Sequenza per bloccaggio del binario sui perni.
Sequence to lock the rail on the pins.

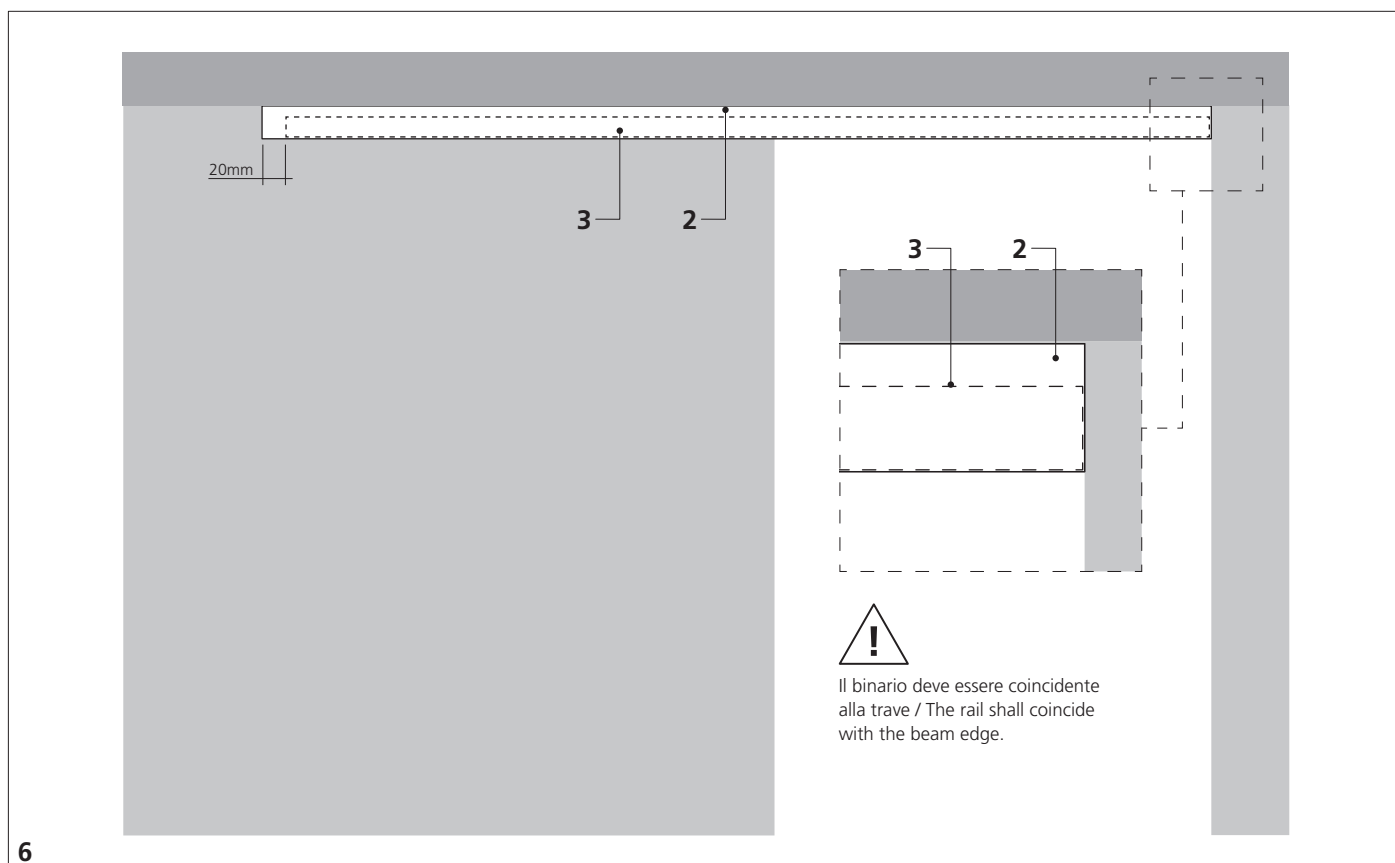

6. Verificare che il binario sia installato correttamente. Il binario è più corto di 20mm rispetto alla trave, nel lato del vano della scomparsa.
6. Check the rail is correctly installed. The rail is shorter 20mm then the beam, on the side that goes inside the wall.

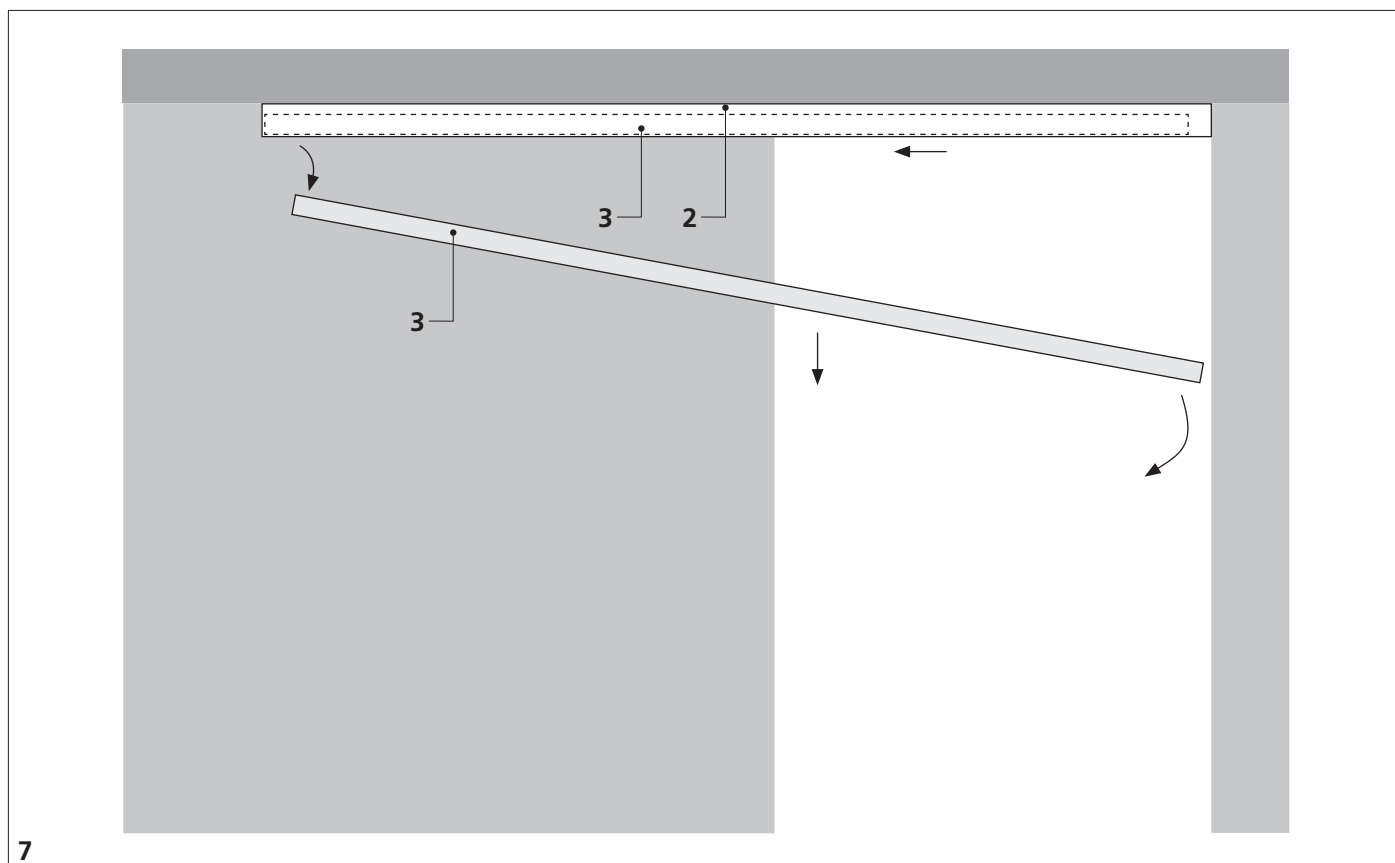

7

7. Togliere il binario effettuando i movimenti inversi rispetto a quanto fatto per il montaggio.

7. Remove the rail doing the opposite steps done to put it on.

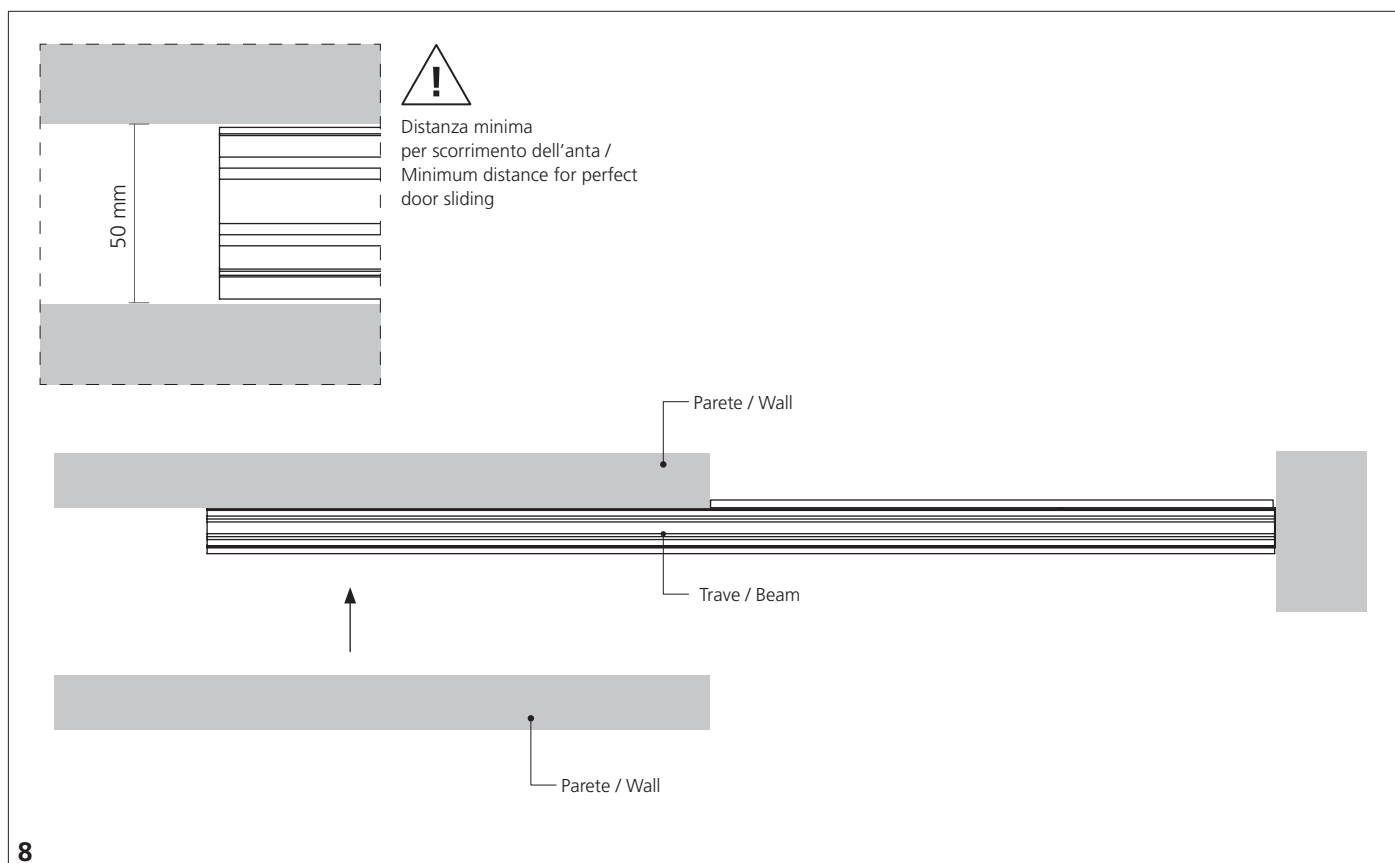

8

8. Chiudere il vano in corrispondenza della porta.

8. Close the opening in correspondence of the door.

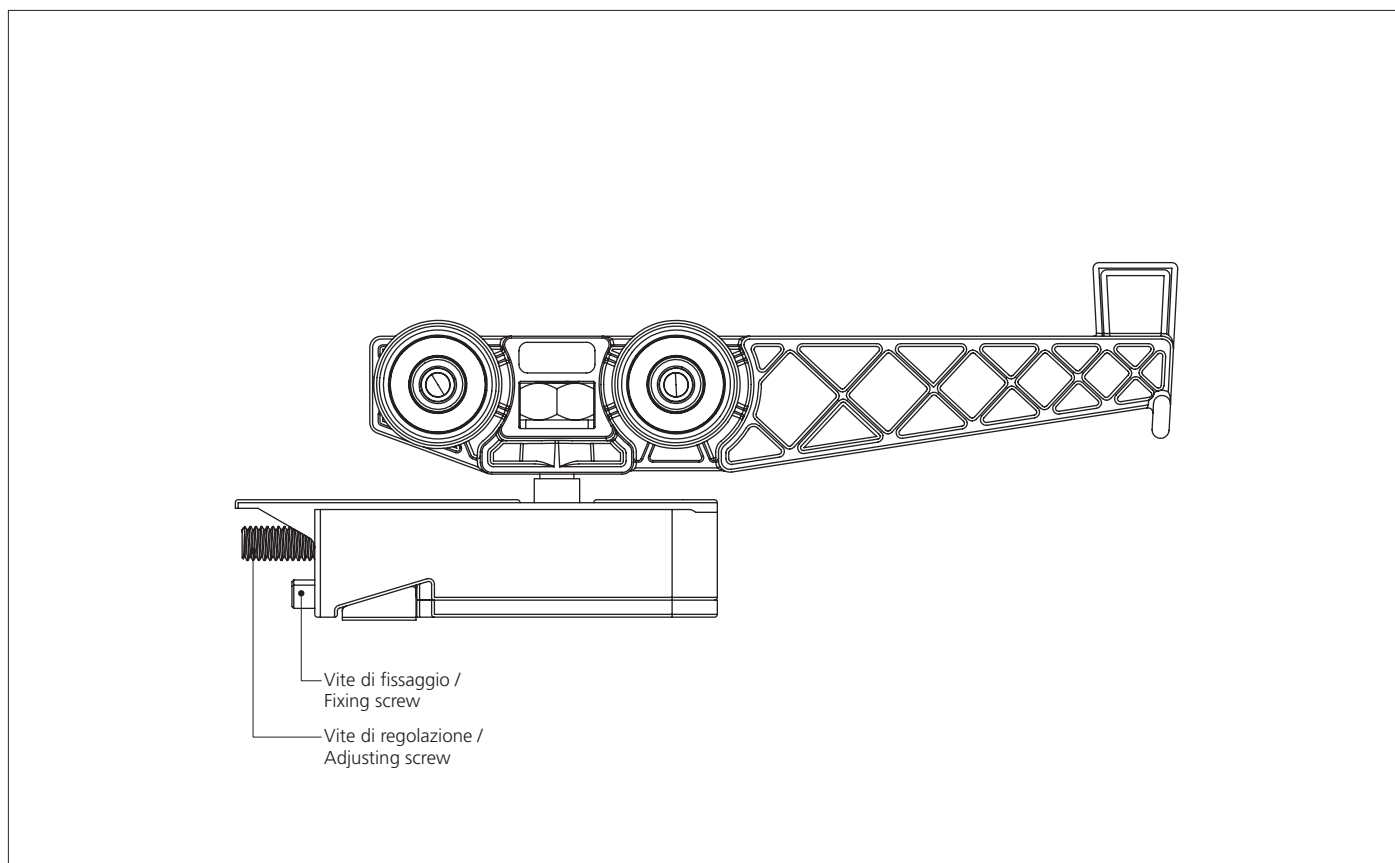

Carrello.
Carriage.

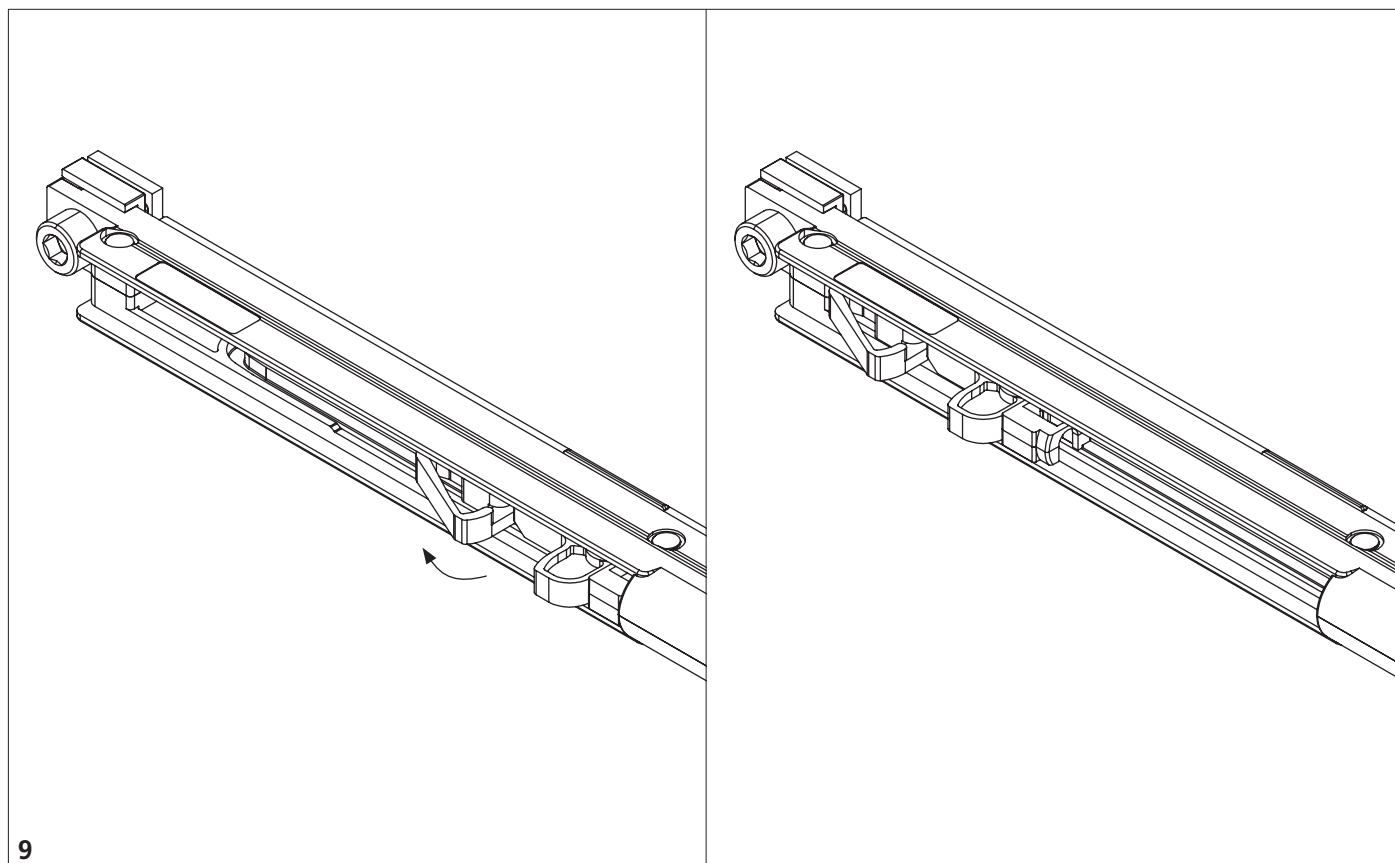

9. Armare i rallentatori.
9. Fit the soft close mechanism.

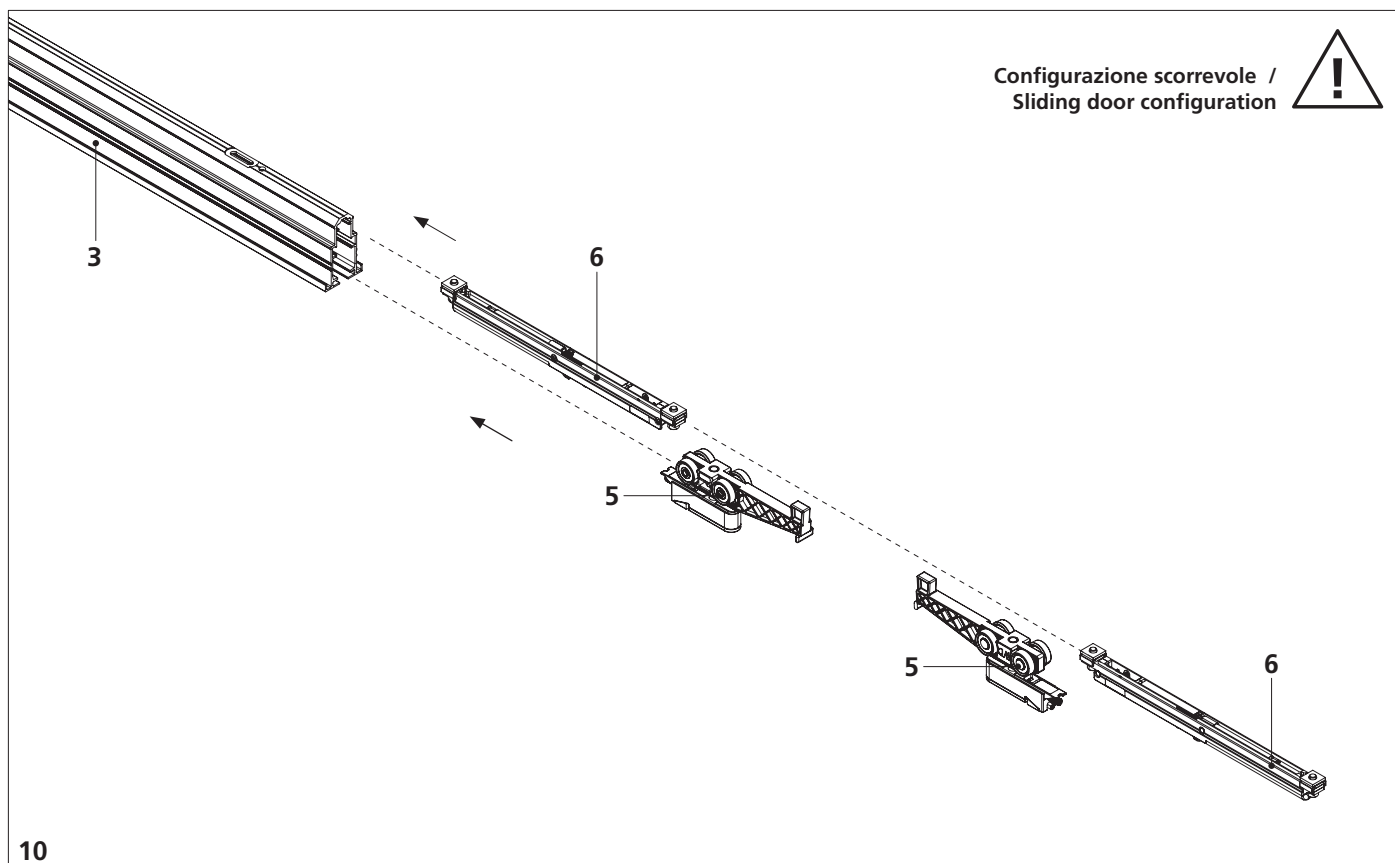

10. Inserire i carrelli e i rallentatori nel binario senza agganciarli fra loro.
10. Insert the carriages and soft close mechanisms without hooking them together.

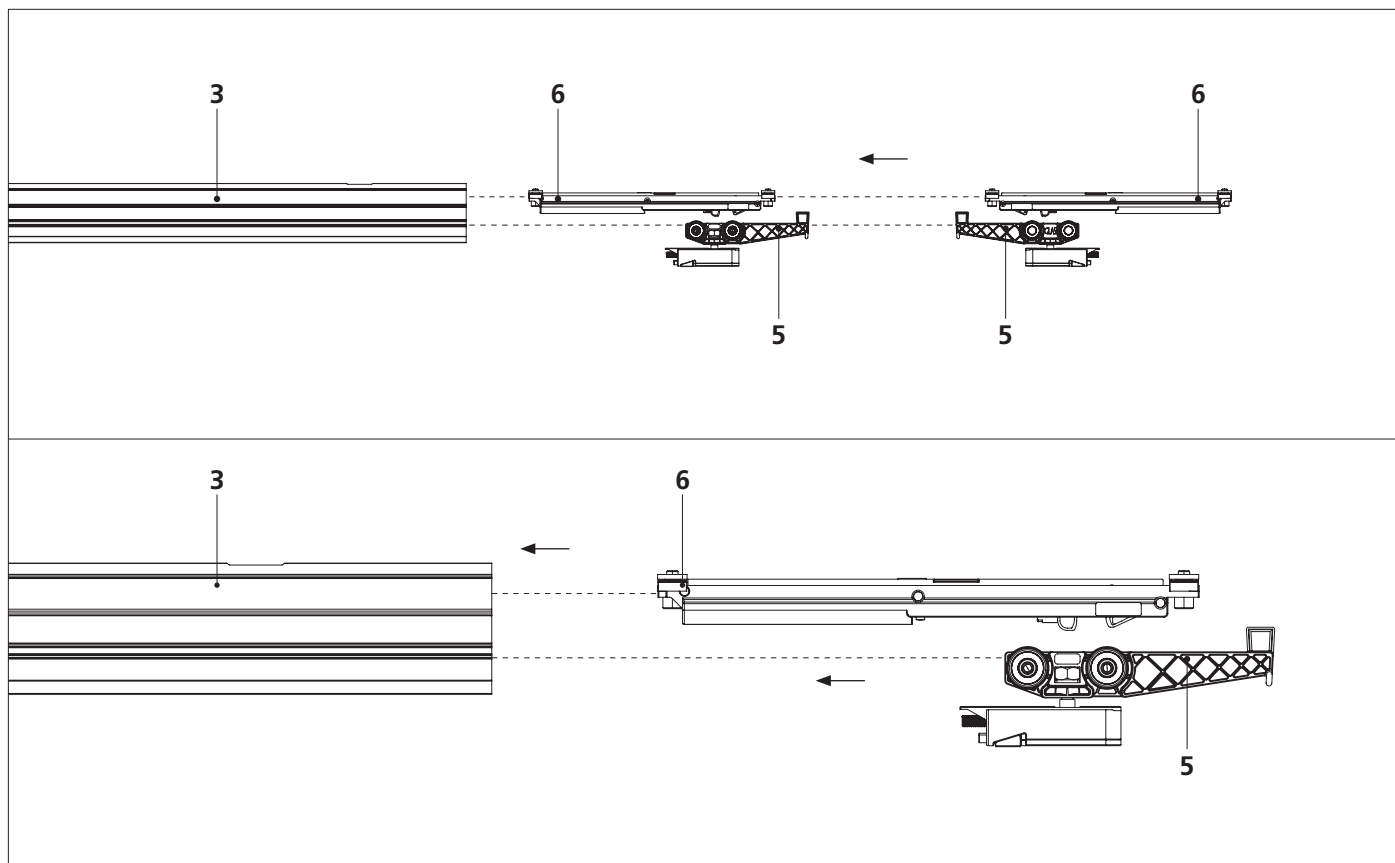

ATTENZIONE: Verificare che i carrelli siano posizionati all'interno dei rallentatori.
ATTENTION: Check that the carriages are positioned inside the soft close mechanisms.



Per configurazioni SENZA profilo di battuta / For configuration WITHOUT door striker profile

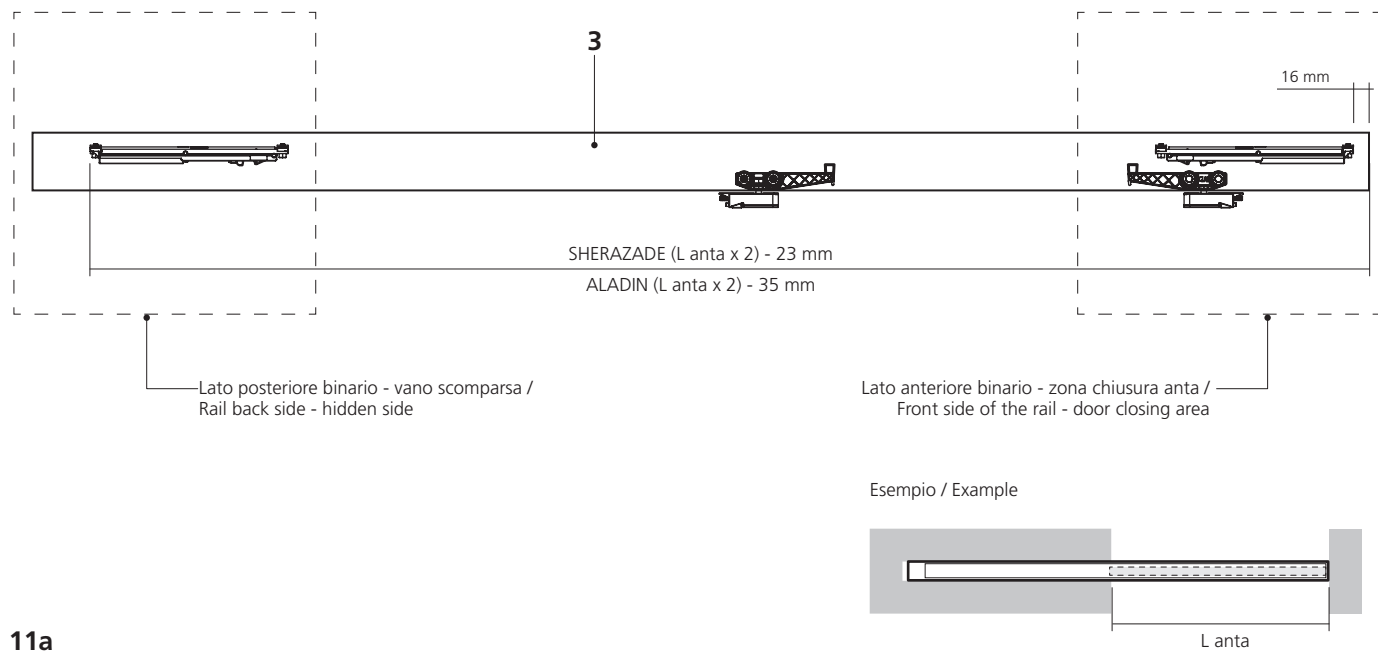

11a

11a. Posizionare i rallentatori alle distanze indicate dalle estremità del binario.
11a. Place the soft close mechanism at the right distances from the rail's edges.



Per configurazioni CON profilo di battuta / For configuration WITH door striker profile

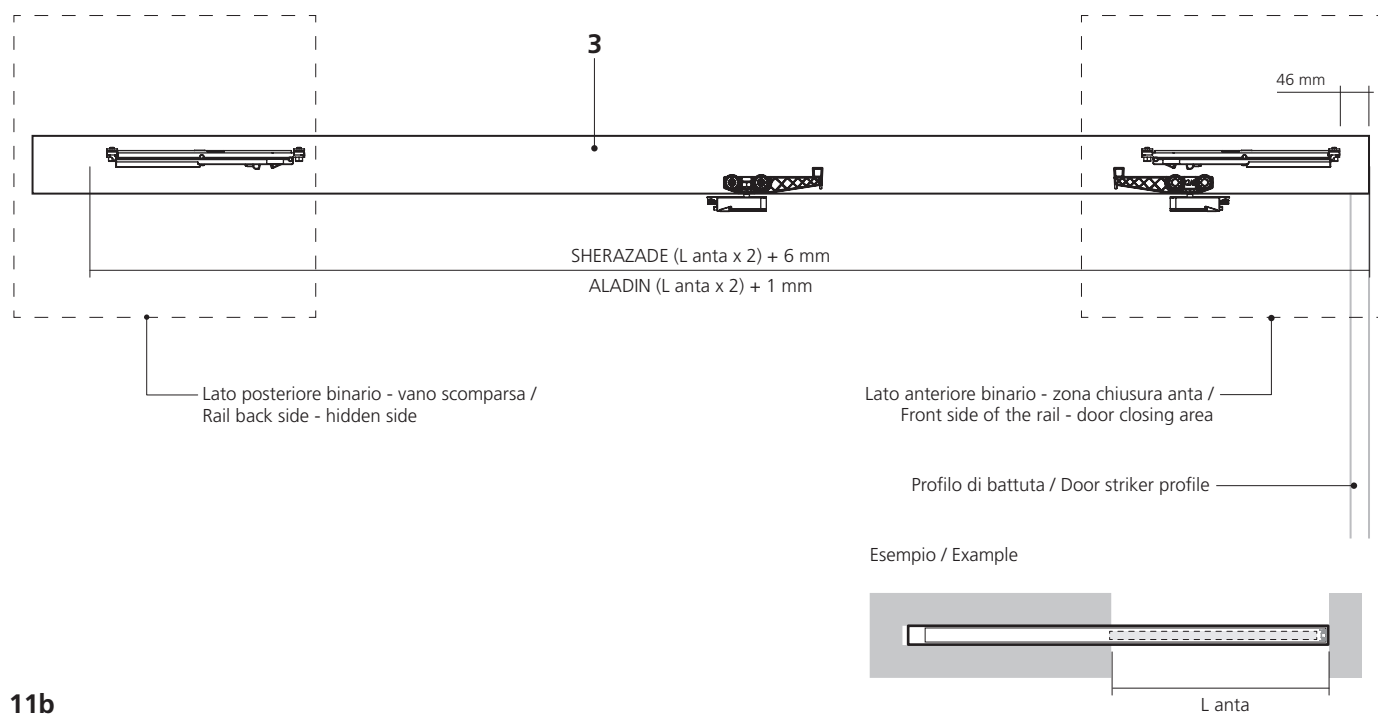

11b

11b. Posizionare i rallentatori alle distanze indicate dalle estremità del binario.
11b. Place the soft close mechanism at the right distances from the rail's edges.

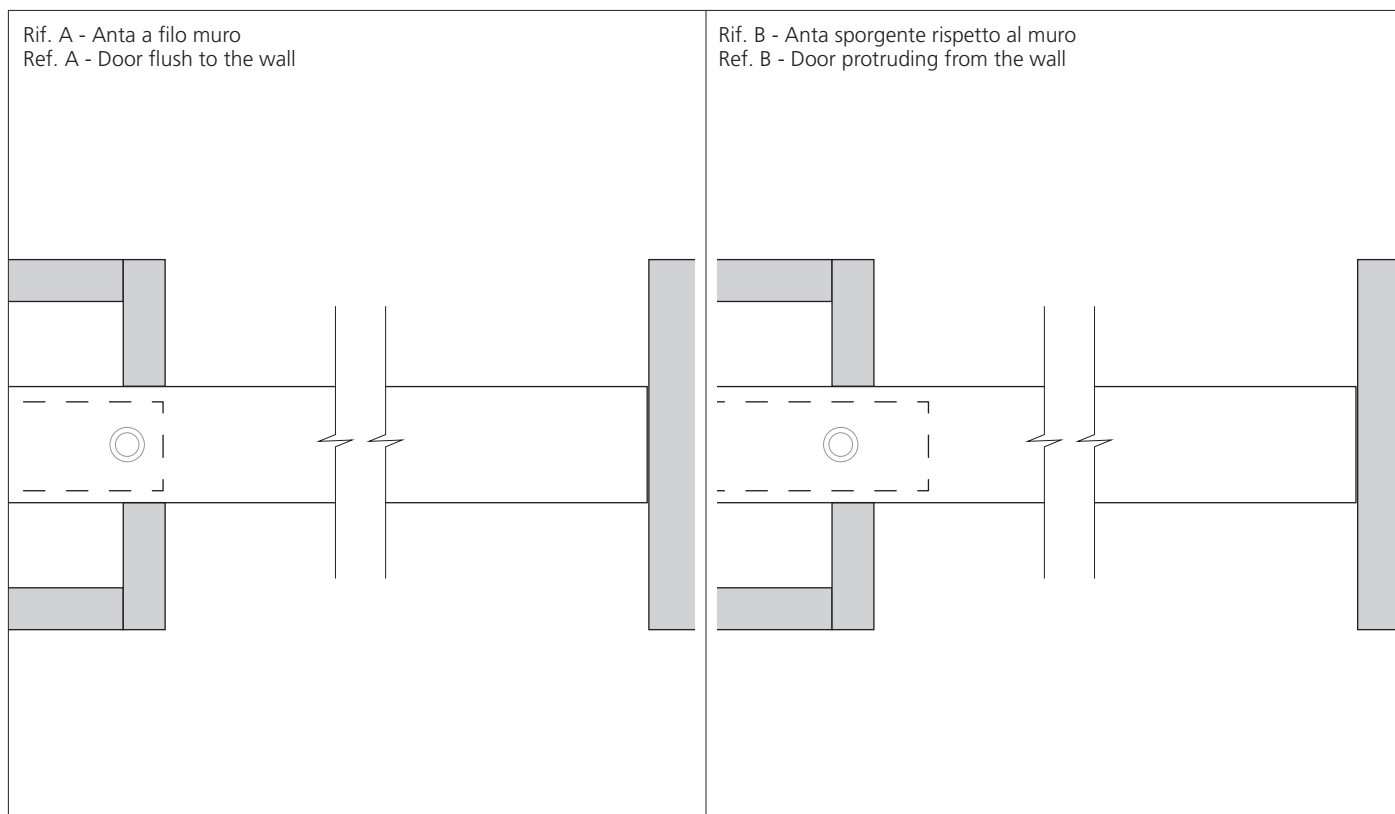

ATTENZIONE: le posizioni dei rallentatori sono valide in caso di ante aperte a filo muro (rif. A). In caso di anta sporgente (rif. B), bisogna modificare la posizione dei rallentatori.

Attention: the position fo the soft closing mechanism are valid in case of door opening flush with the wall (ref. A). In the other case (ref. B) it must change the positon of the soft closing mechanism.

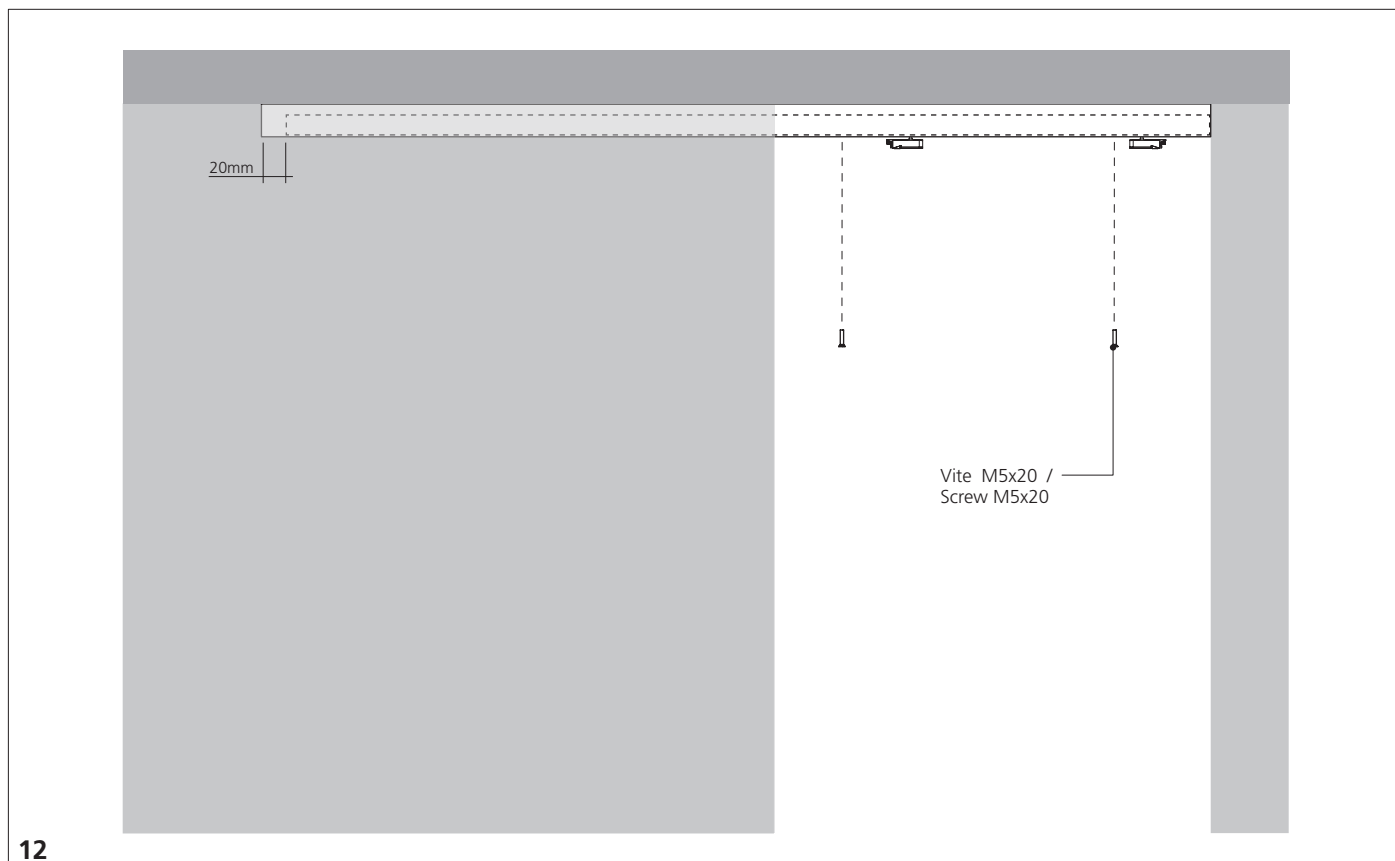

12. Rimontare il binario in posizione e inserire le viti di sicurezza nella parte a vista del binario.
12. Install back the rail in position and install the safety screws in the visible part of the rail.

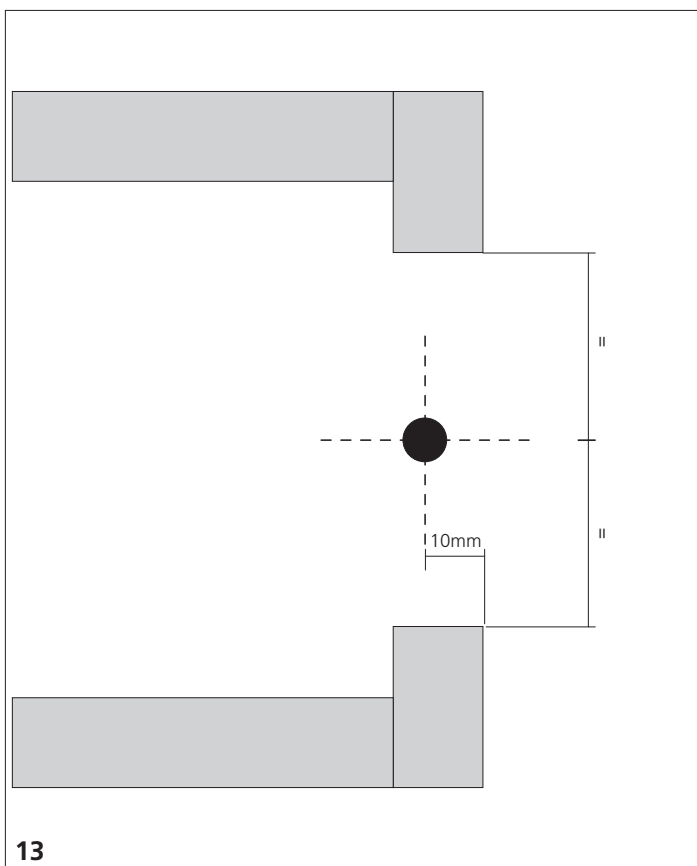

13

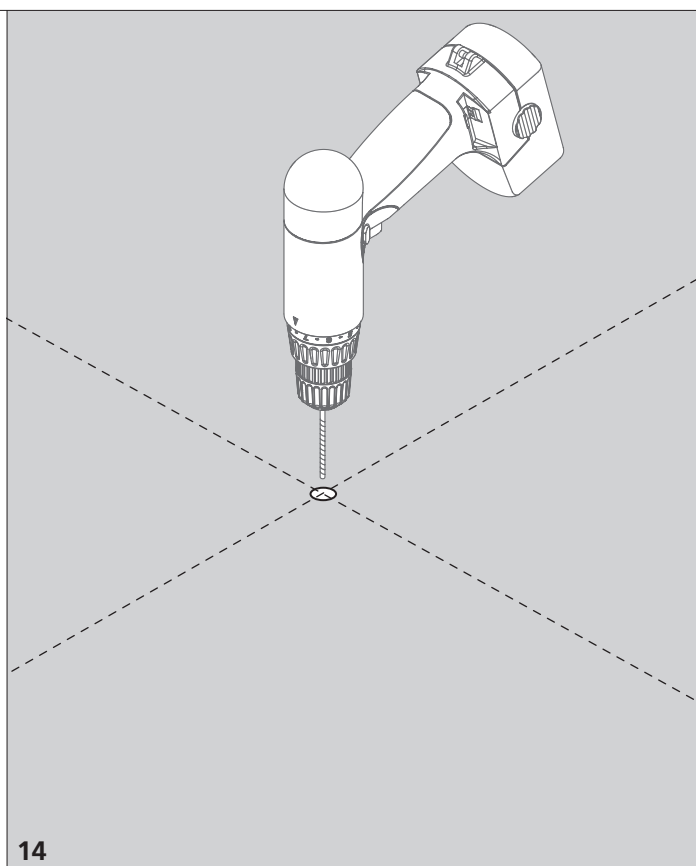

14

13. Il perno deve essere posizionato in centro all'anta e a 10 mm dal bordo della parete./ 14. Forare nel punto prestabilito.
 13. The floor pin has to be placed in the middle of the door and at 10 mm from the wall edge/ 14. Drill the floor in predetermined point.

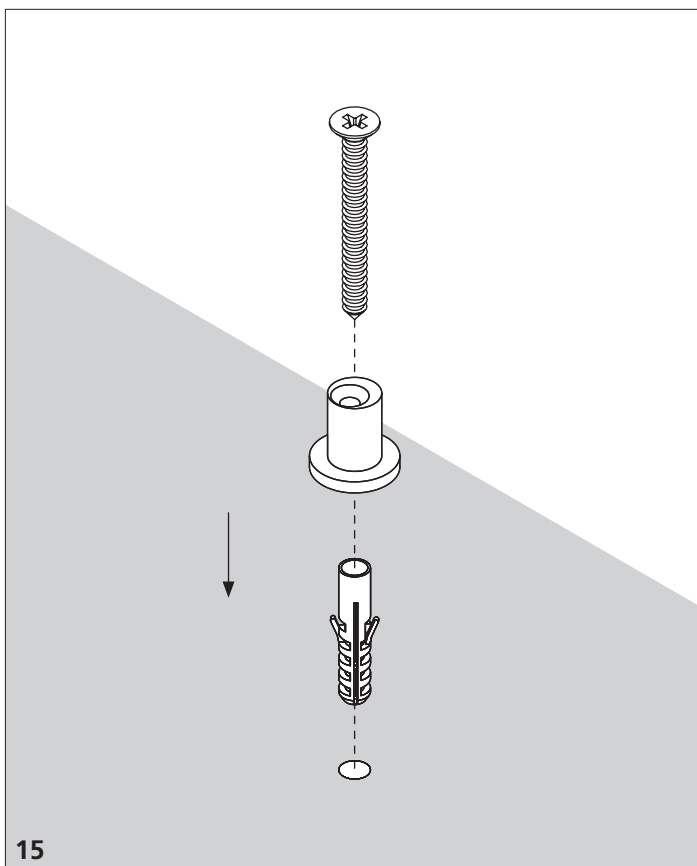

15

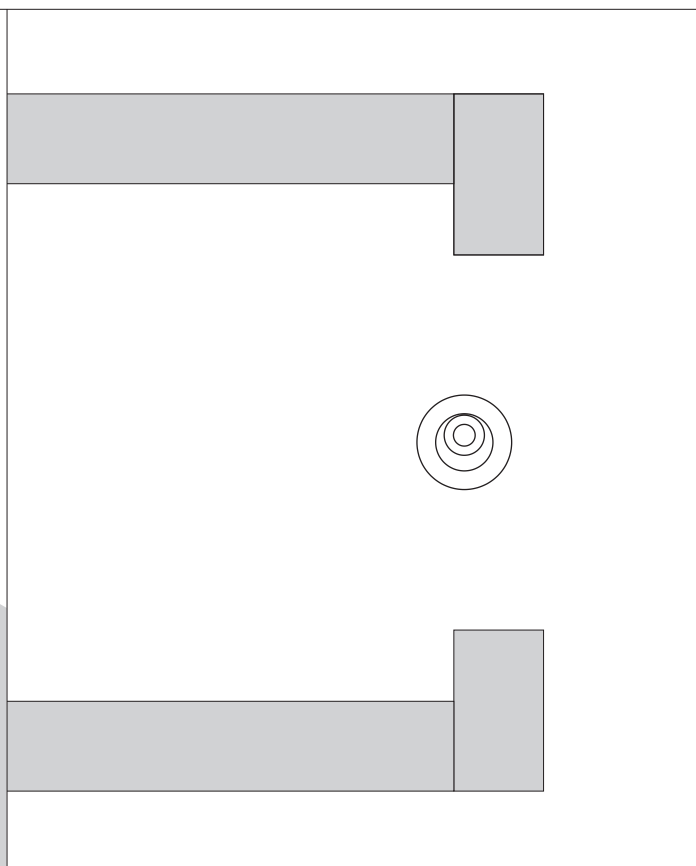

15. Fissare i perni a pavimento.
 15. Fix the pins to the floor.

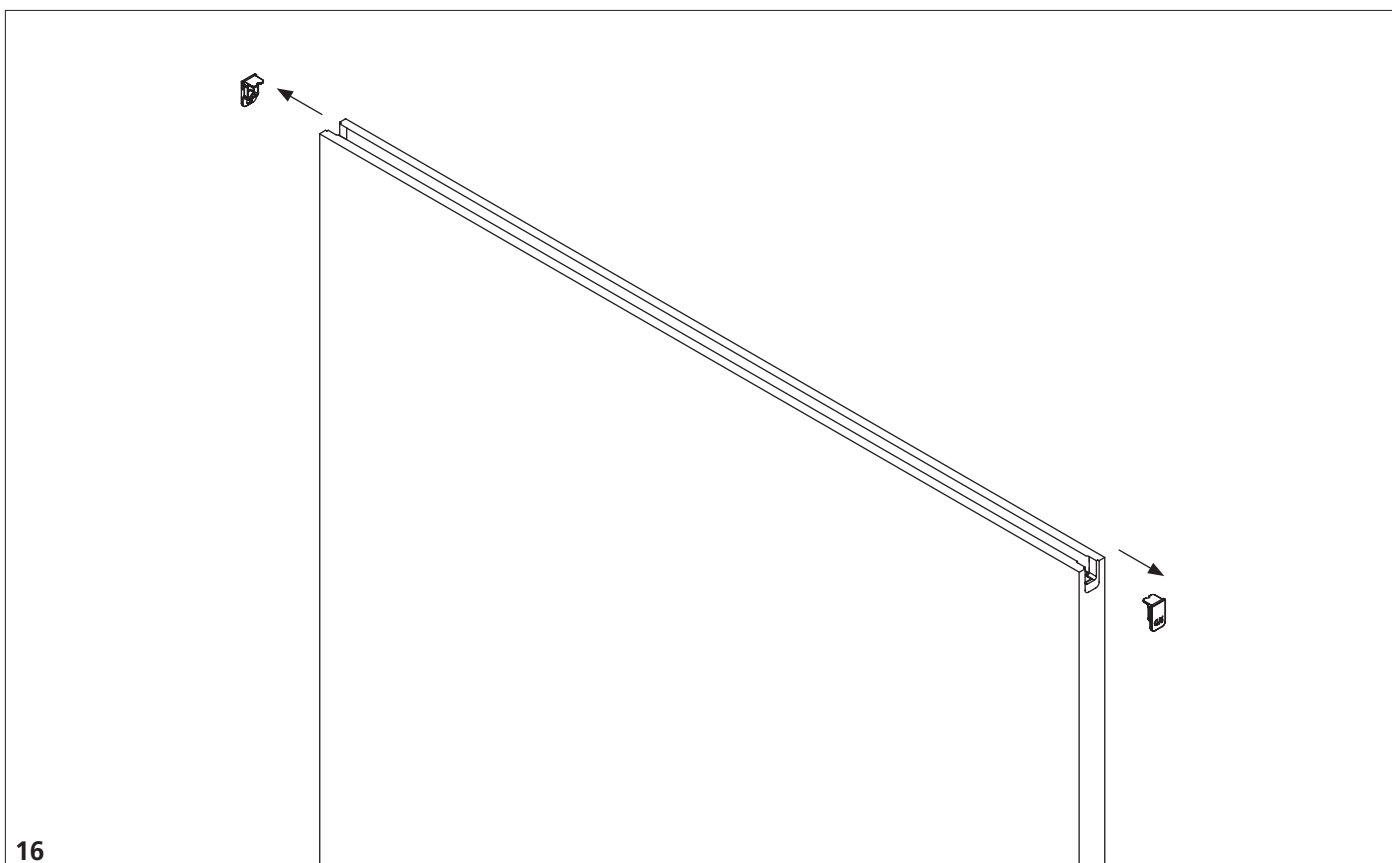

16

16. Togliere il tappo copri carrello da entrambi i lati dell'anta.
 16. Remove the cover of the carriages from both sides of door.

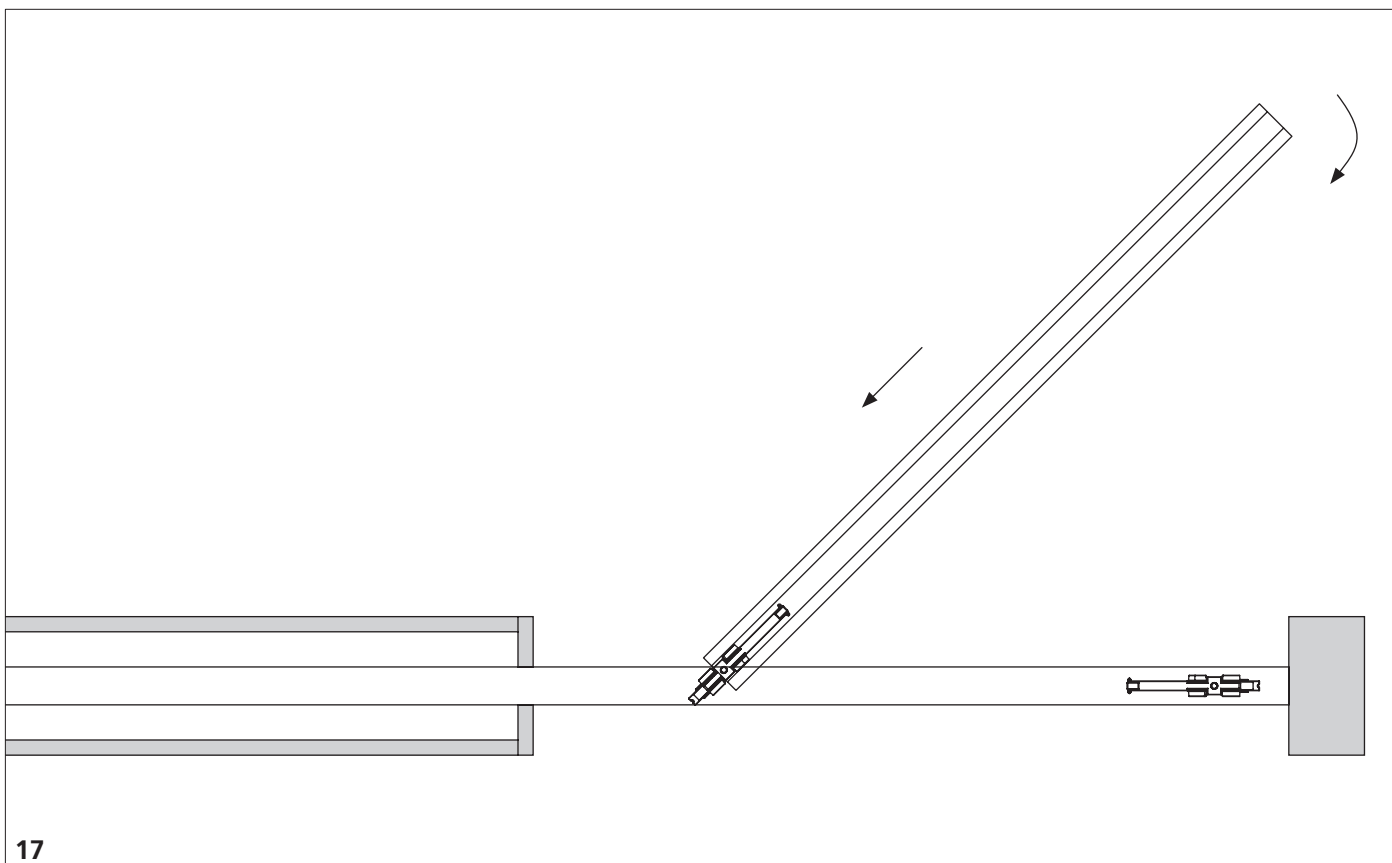

17

17. Inclinare l'anta ed infilare il primo carrello (lato posteriore).
 17. Incline the door and insert the first carriage (back side).

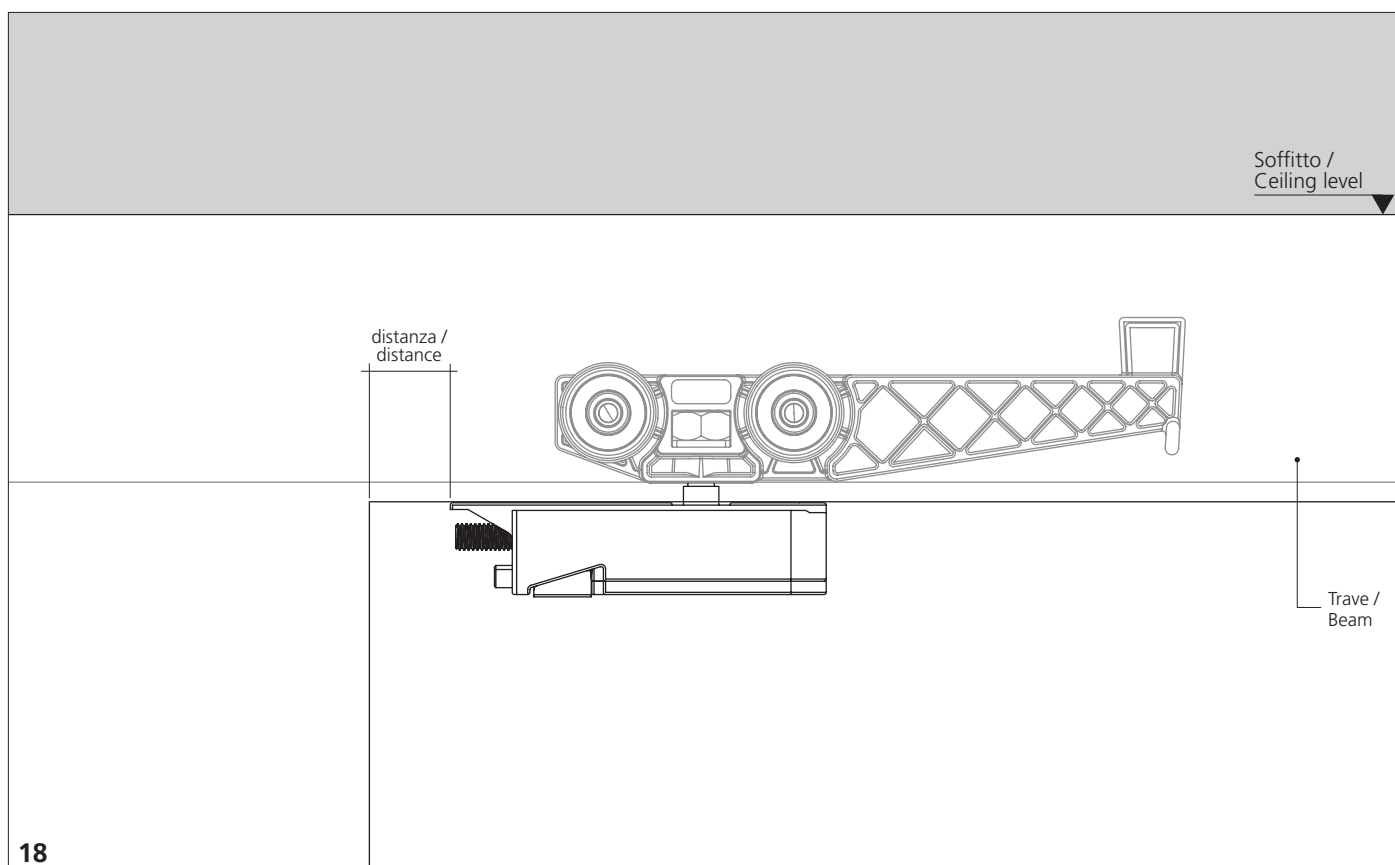

18. La lavorazione presente sul traverso dell'anta identifica la posizione del carrello rispetto al bordo dell'anta stessa.
 18. Machining on the door's crosspiece identifies the position of the carriage in relation to the door's edge.

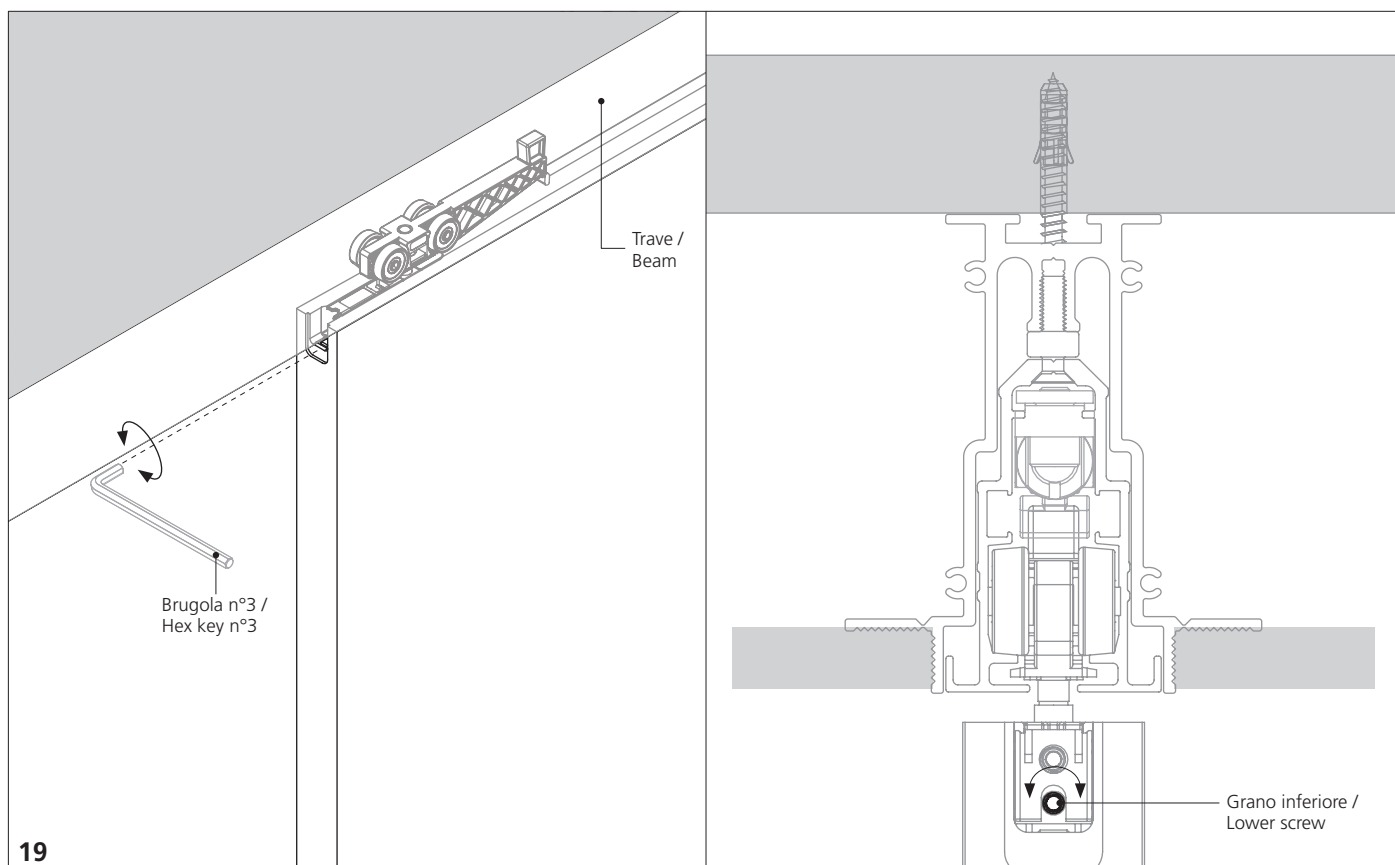

19. Avvitare il grano inferiore per bloccare il carrello.
 19. Screw the lower grain to lock the carriage.

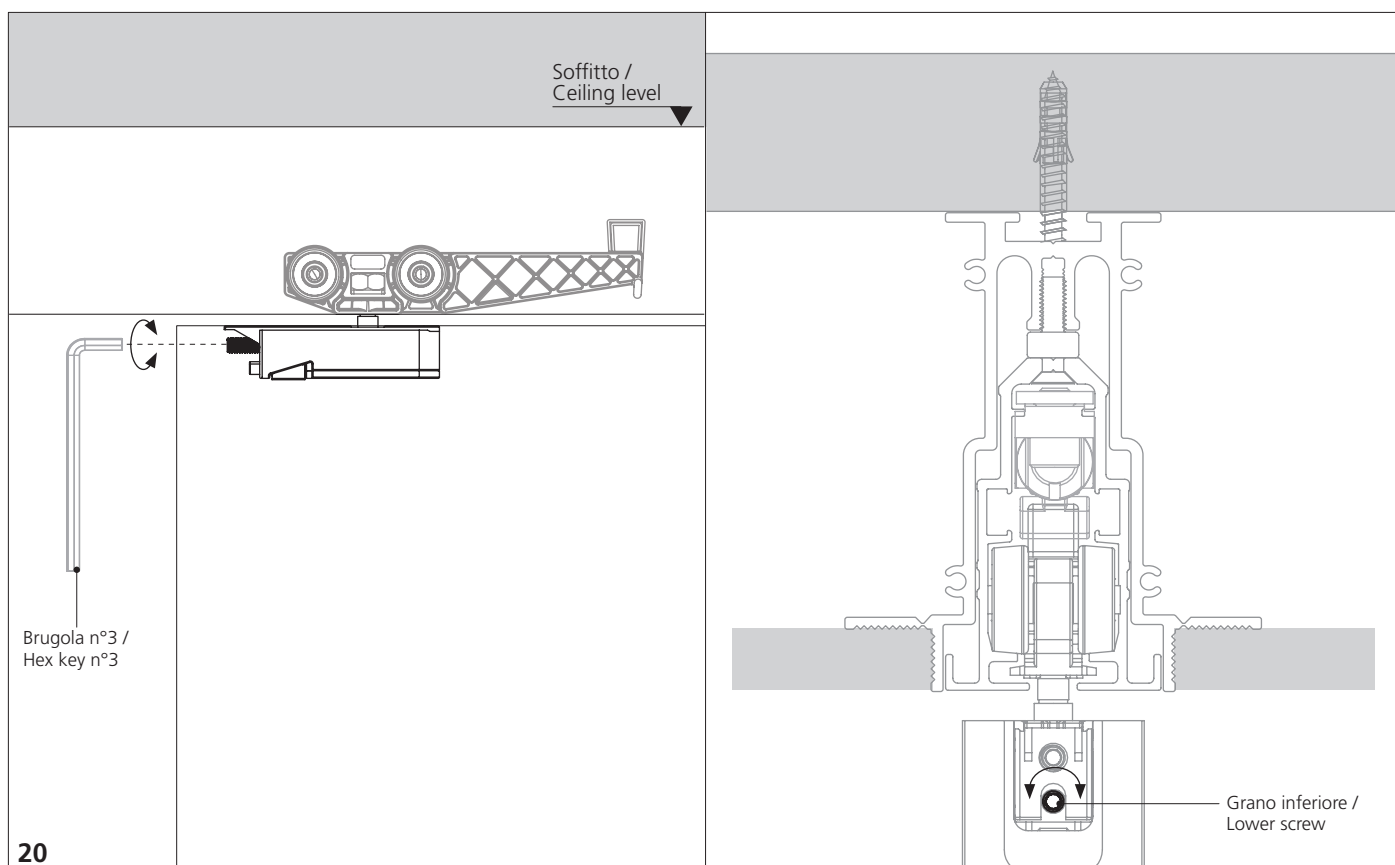

20. Per una regolazione millimetrica dell'anta, agire sulla vite superiore presente nel carrello di scorrimento.
 20. To adjust the door millimetrically, act on the upper screw placed in the sliding carriage.

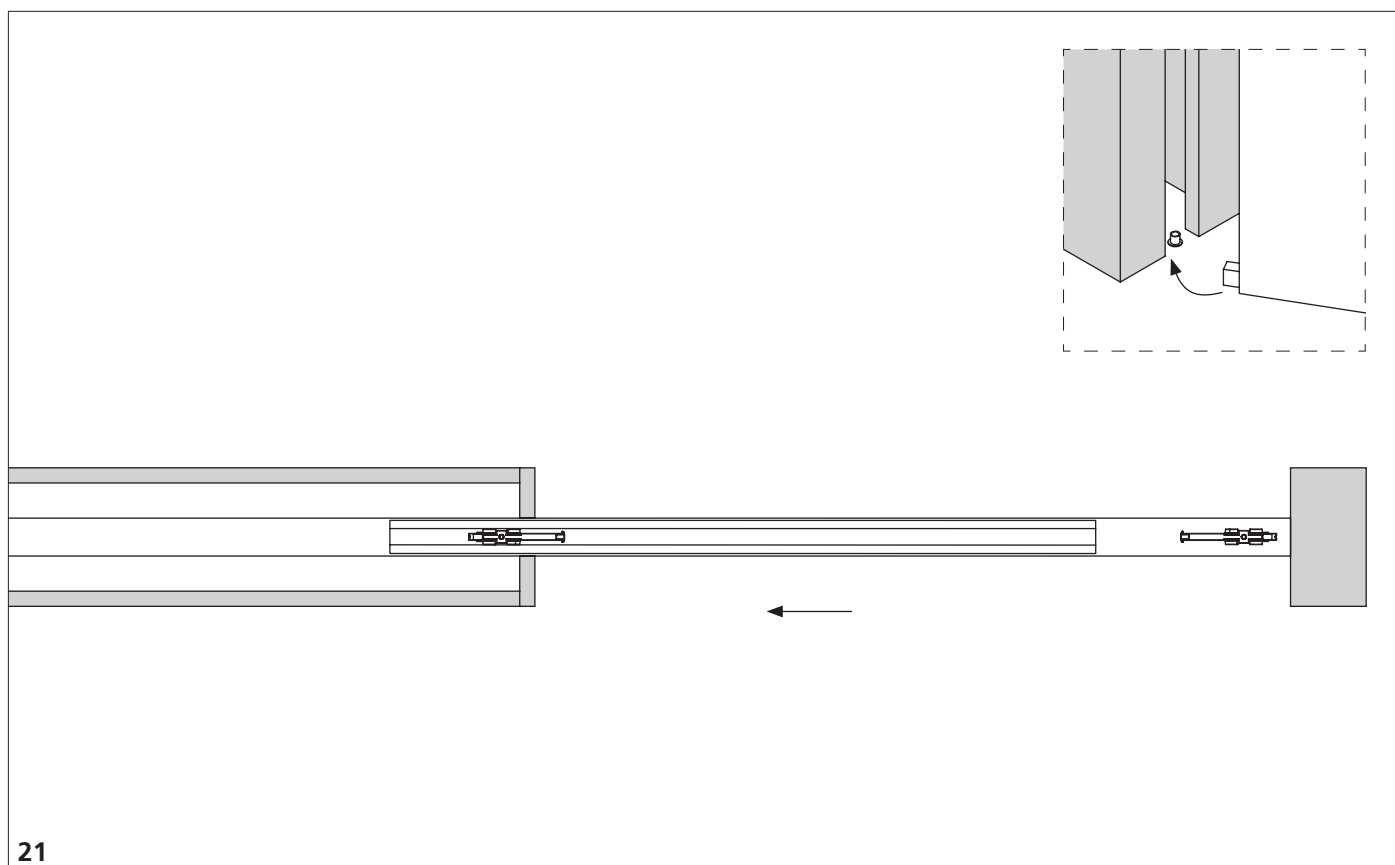

21. Calzare l'anta sul perno a pavimento e farla scorrere all'interno del vano.
 21. Place the door on the floor pin and allow to slide into the compartment.

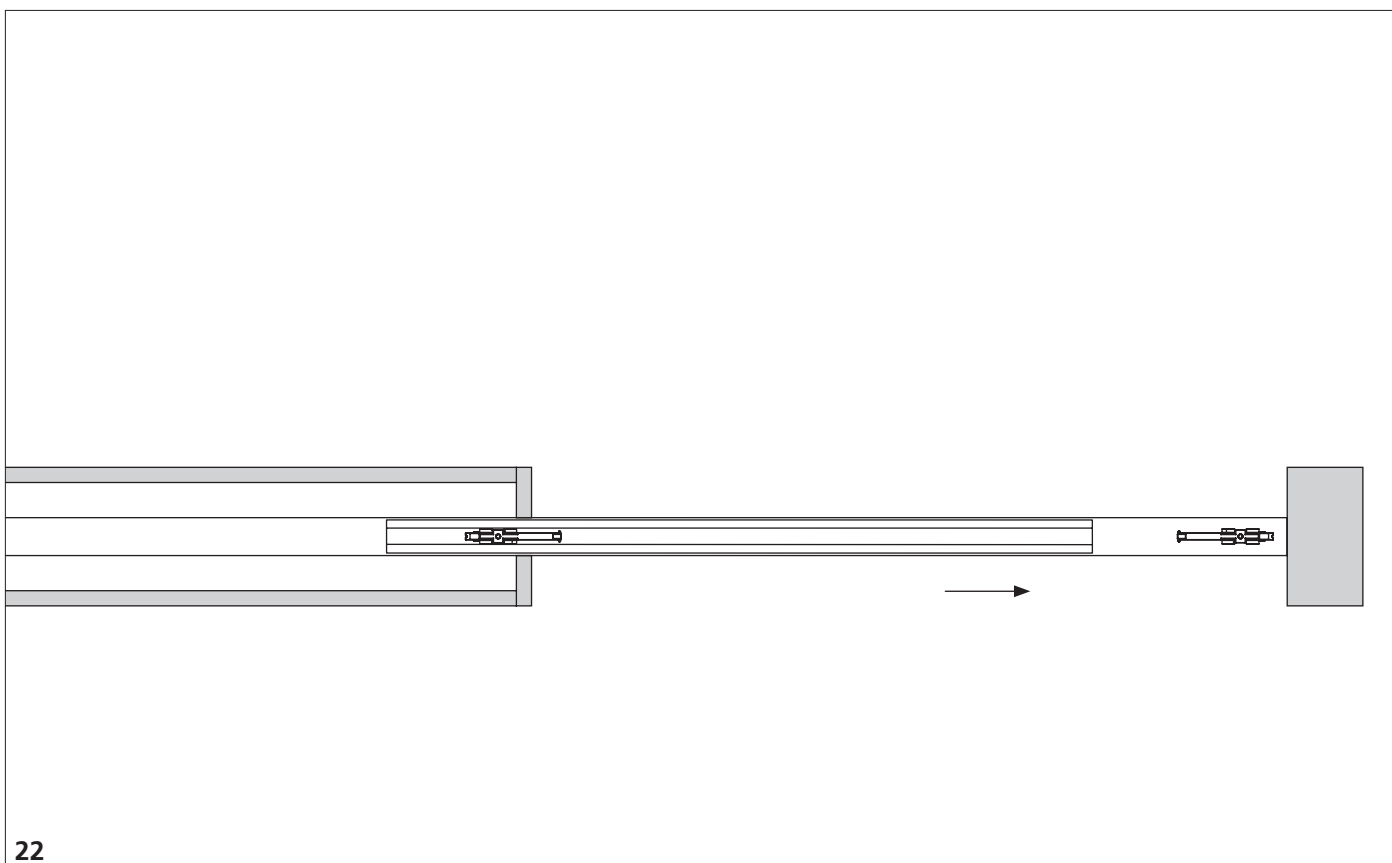

22

22. Infilare l'anta sul secondo carrello (frontale).
22. Insert the door on the second (front) sliding carriage.

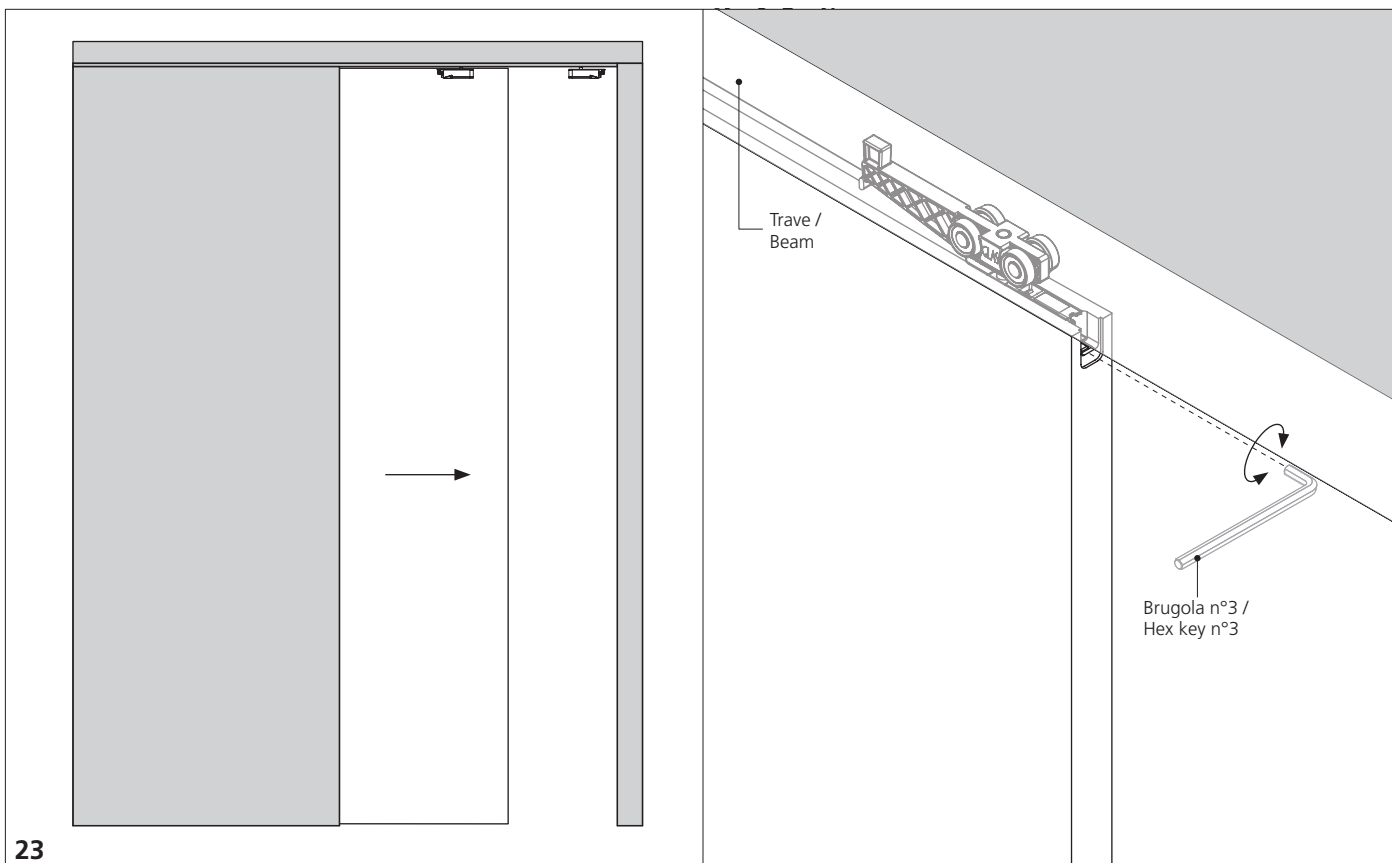

23

23. Fissare il secondo carrello all'anta.
23. Fix the sliding carriage to the door.

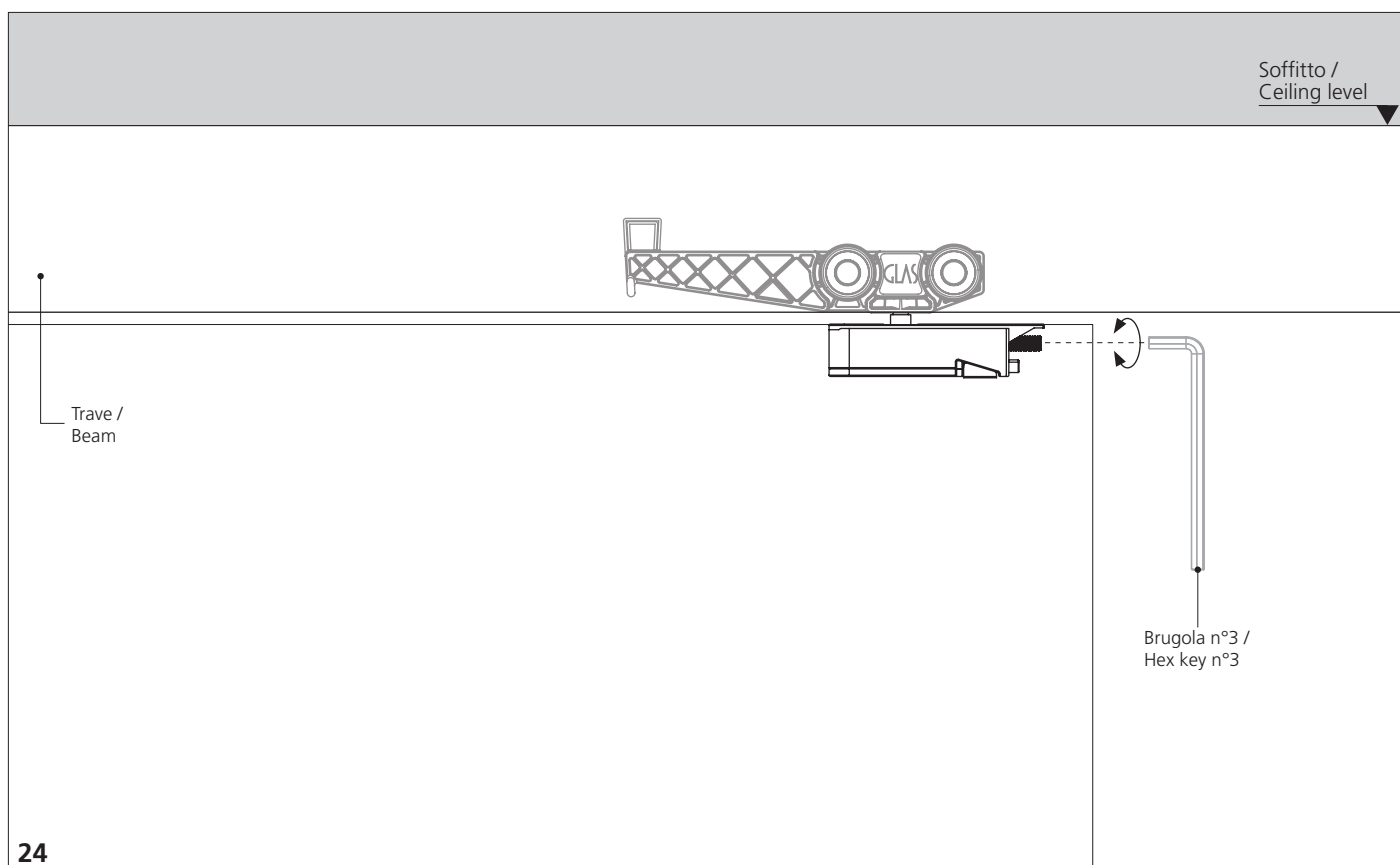

24. Effettuare le regolazioni per un perfetto scorrimento dell'anta.
24. Make adjustments in order to find a perfect door sliding.

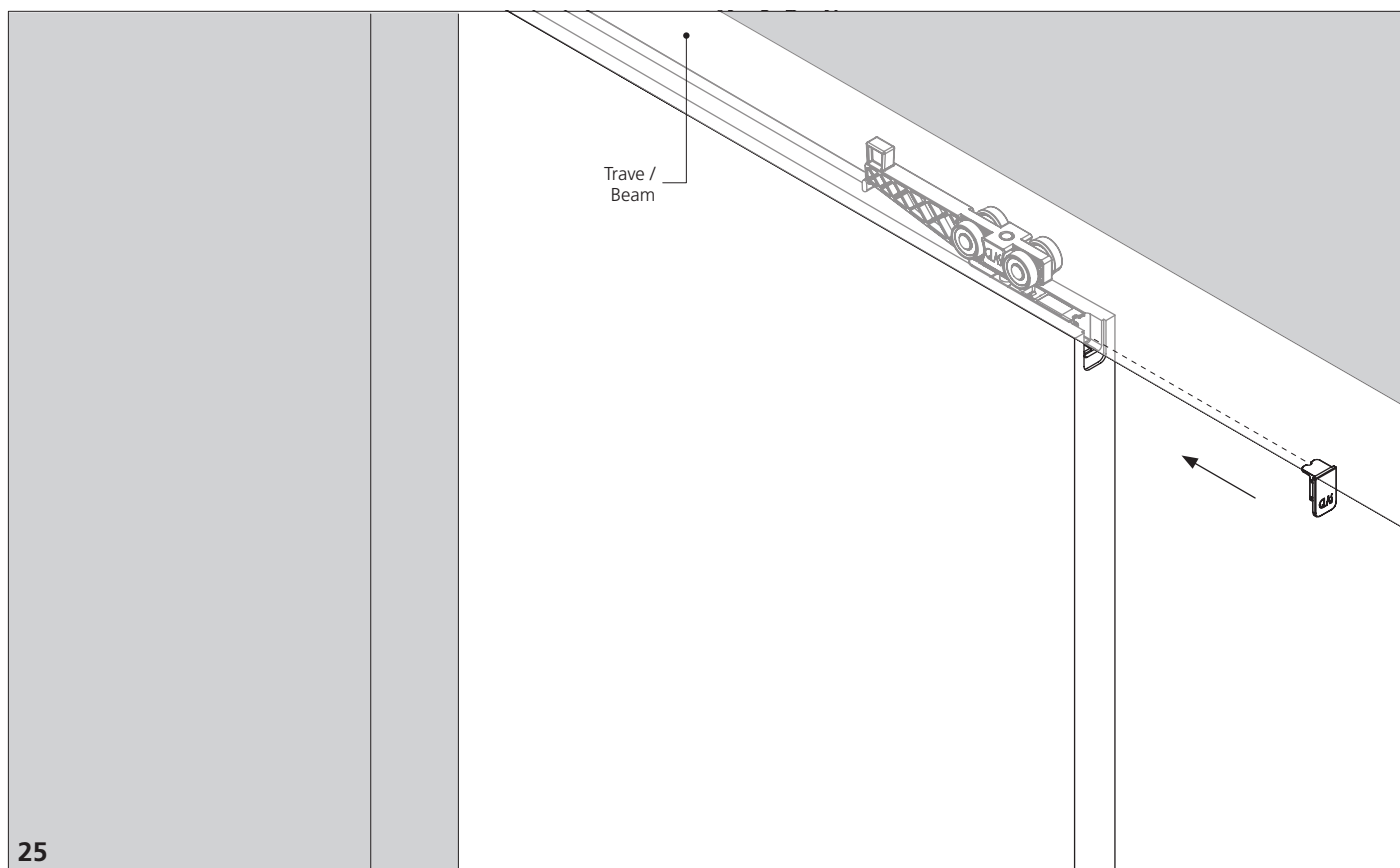

25. Posizionare a pressione il tappo copri carrello sulla parte anteriore dell'anta.
25. Place the cover on the front side of the door by pressing.



Sistema scorrevole per porta a scomparsa | Anta doppia | Montaggio
Pocket door sliding system | Double door | Installation

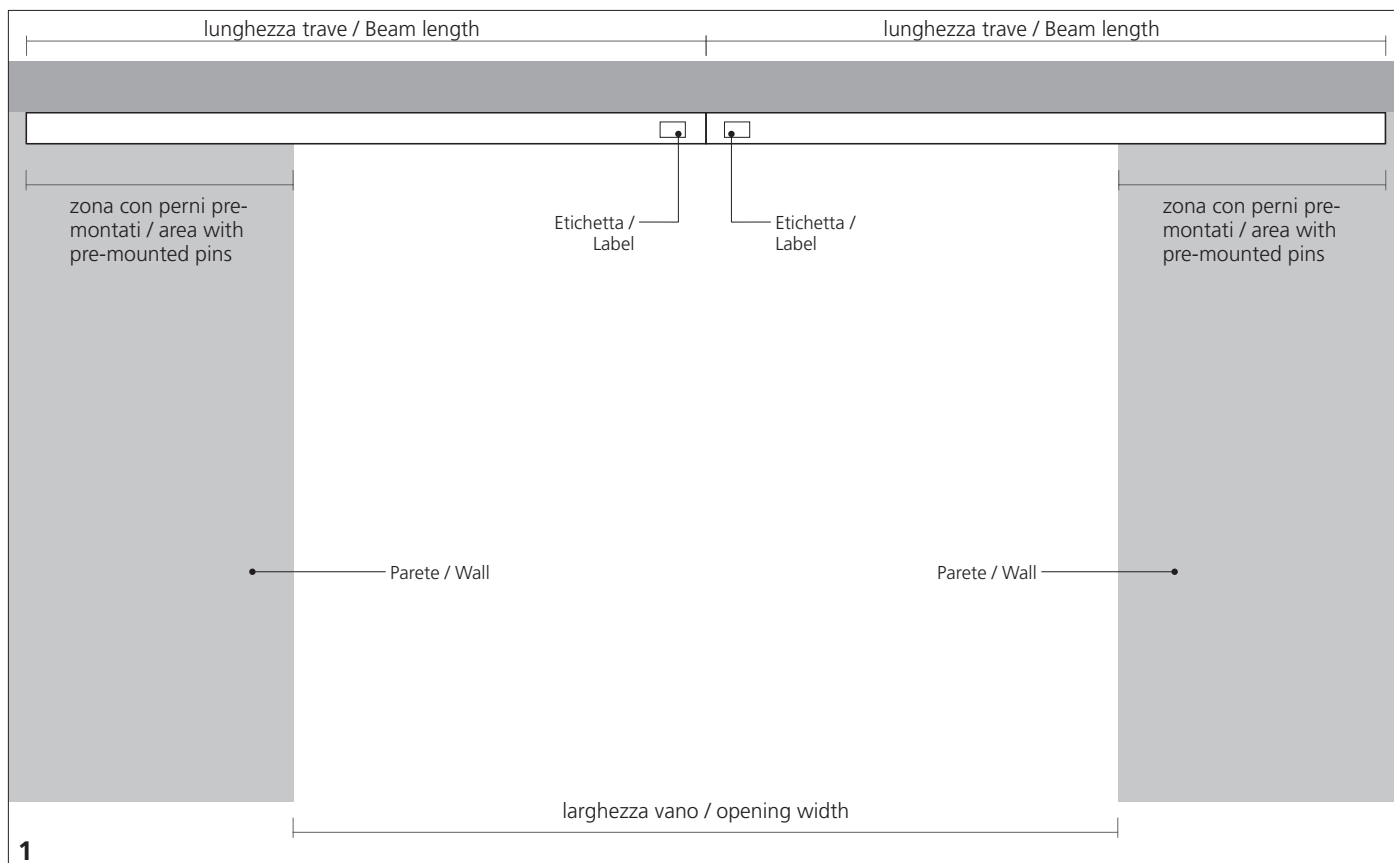

1. Fissare la trave, facendo attenzione al verso di montaggio: l'etichetta indica il lato da lasciare nel passaggio libero.
 1. Fix the beam, paying attention to the sliding direction: the level indicates the side to be left in the opening passage.

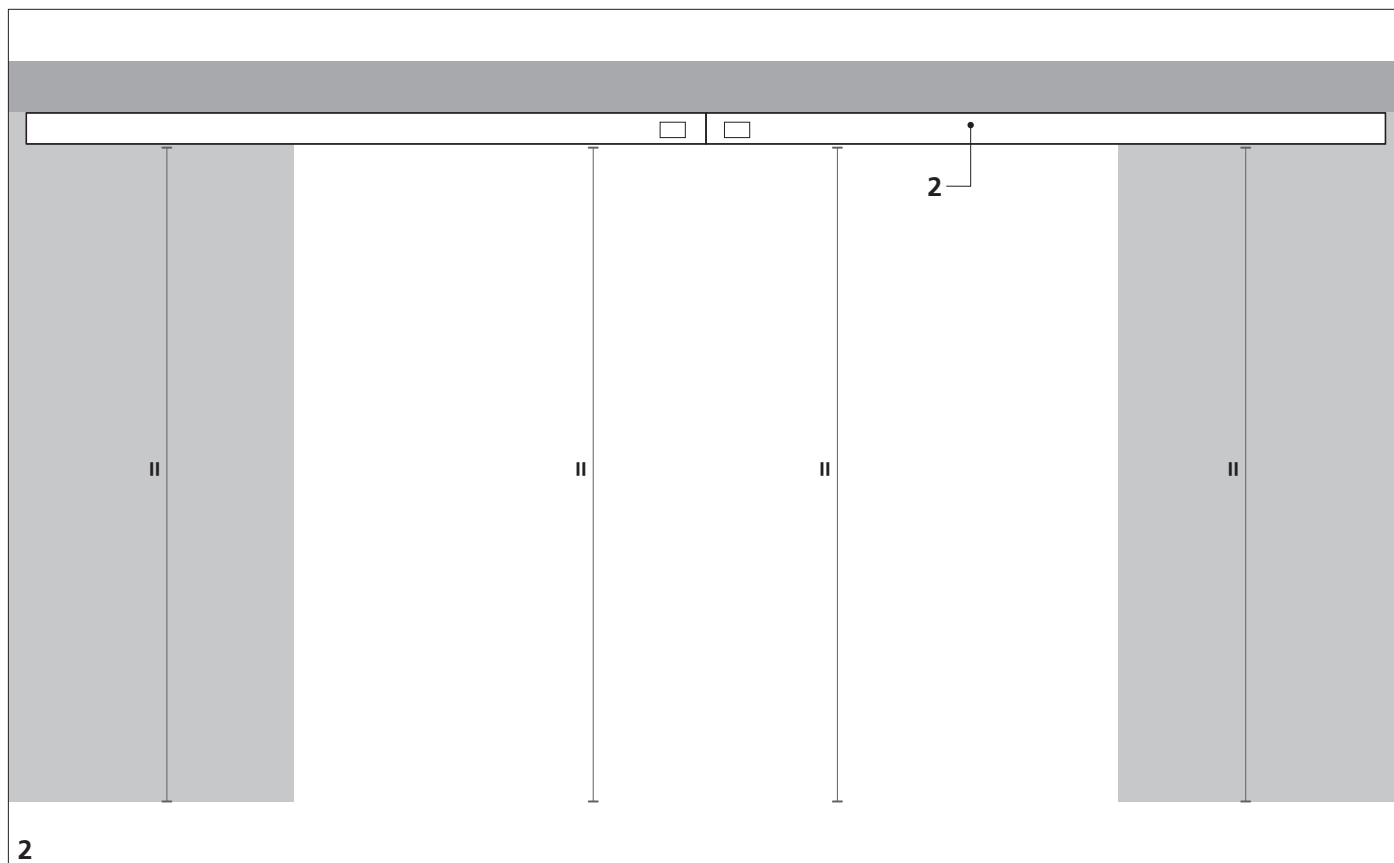

2. Verificare che la trave venga montata senza che ci sia una flessione. La trave deve essere in bolla.
 2. Check the beam is installed without a bending. The beam must be levelled.

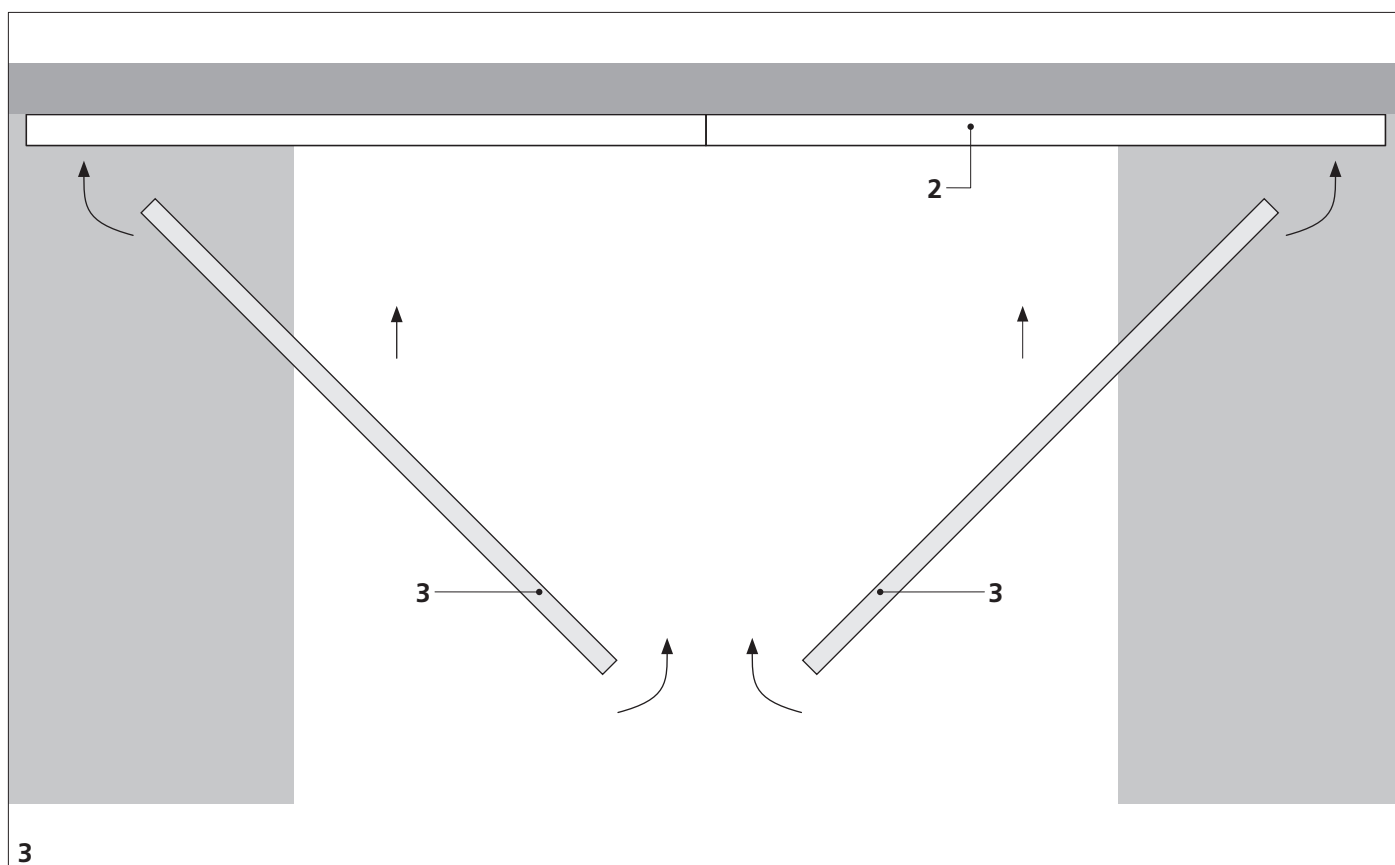

3. Inclinare i binari ed inserirli nella trave, facendo corrispondere i perni con le sedi poste sui binari stesso.
 3. Incline the rails and put it into the beam, making coincide the pins with the holes on the rails.

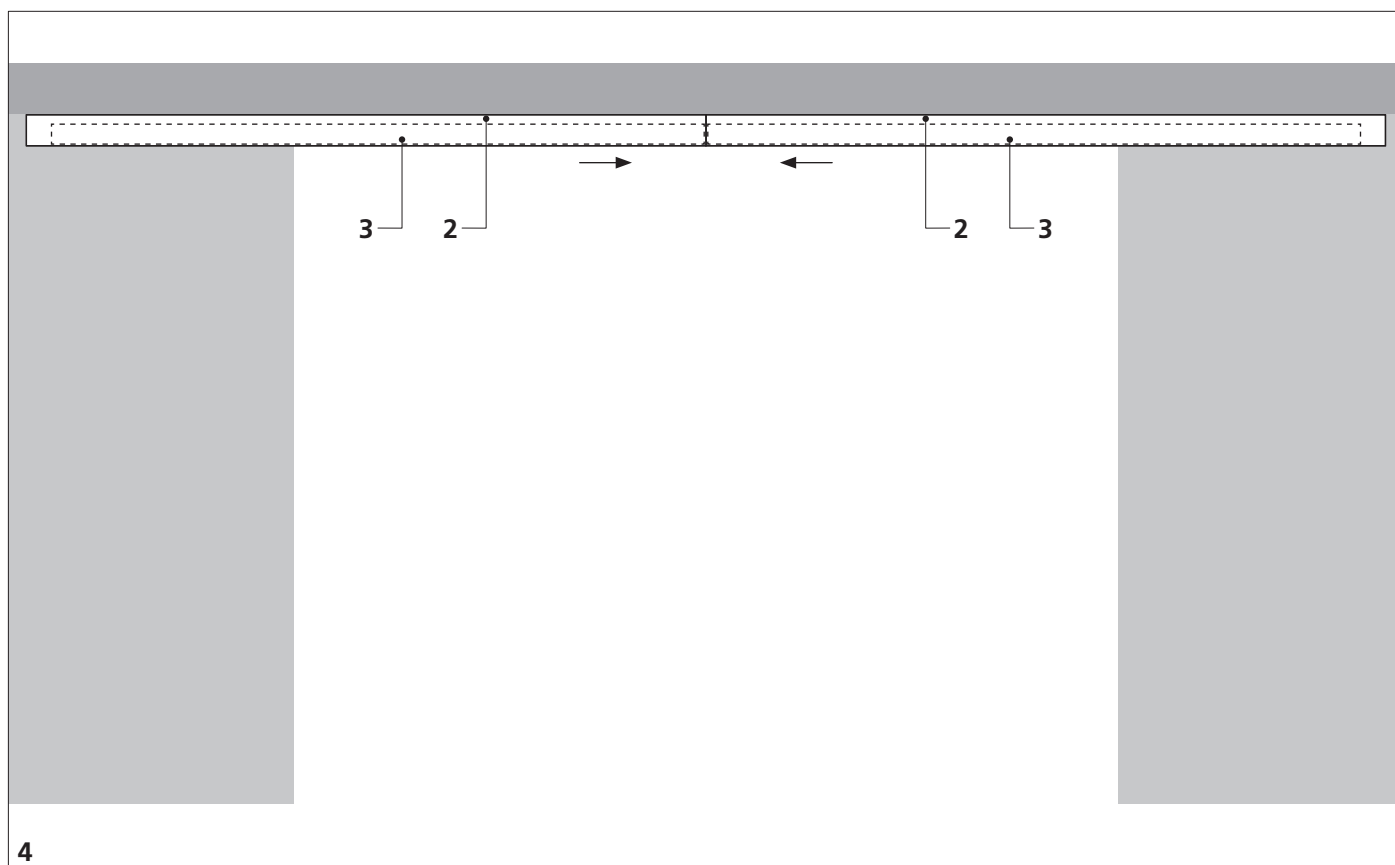

4. Tirare il binario verso la zona frontale della trave per bloccarlo in posizione.
 4. Pull the rail towards the front area of the beam to lock it into position.

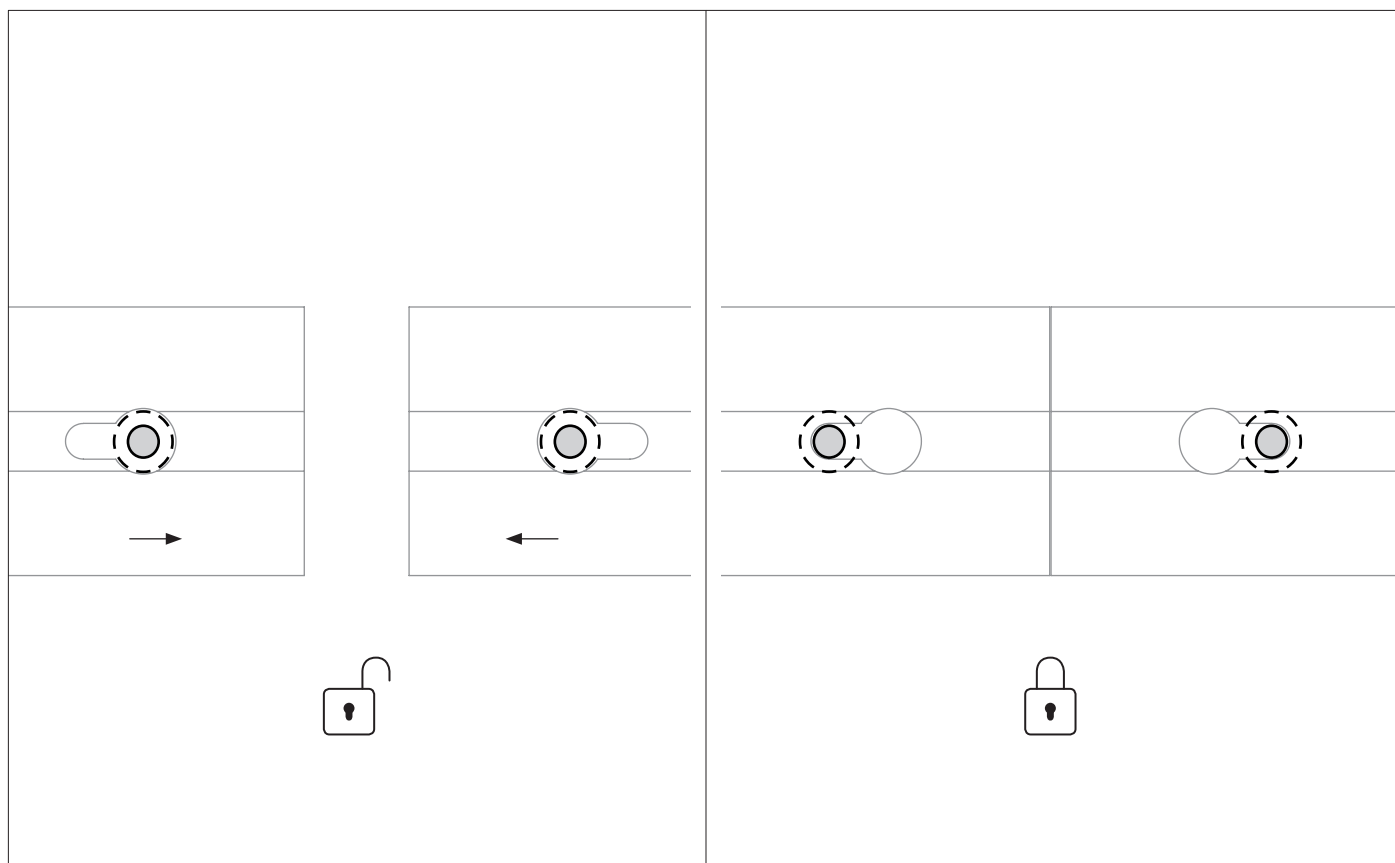

Sequenza per bloccaggio del binario sui perni.
Sequence to lock the rail on the pins.

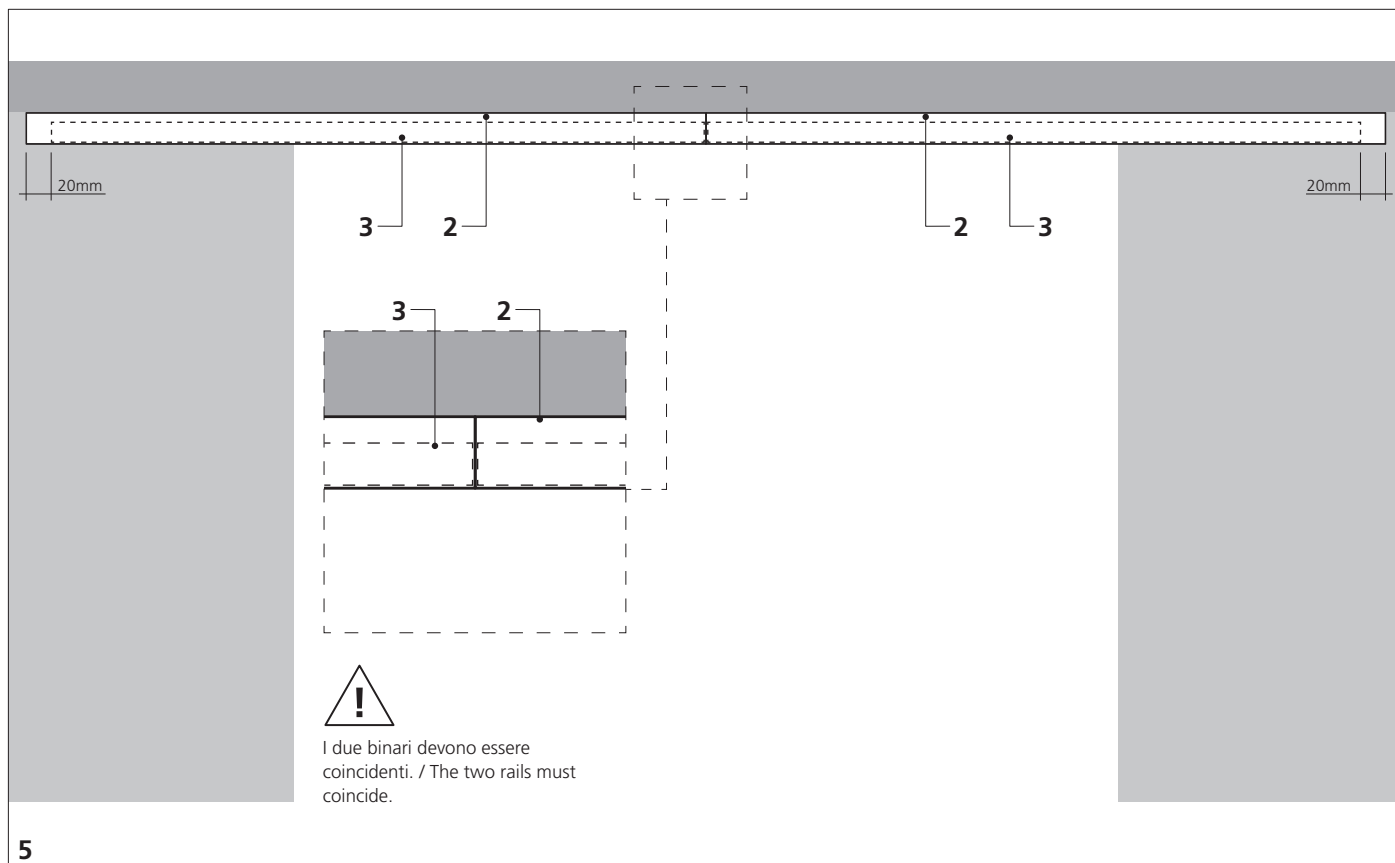

5. Verificare che i binari siano installati correttamente. Ogni binario è più corto di 20mm rispetto alla trave, nel lato del vano della scomparsa.
5. Check that the rails are correctly installed. Each rail is shorter 20mm then the beam, on the side that goes inside the wall.

Pocket

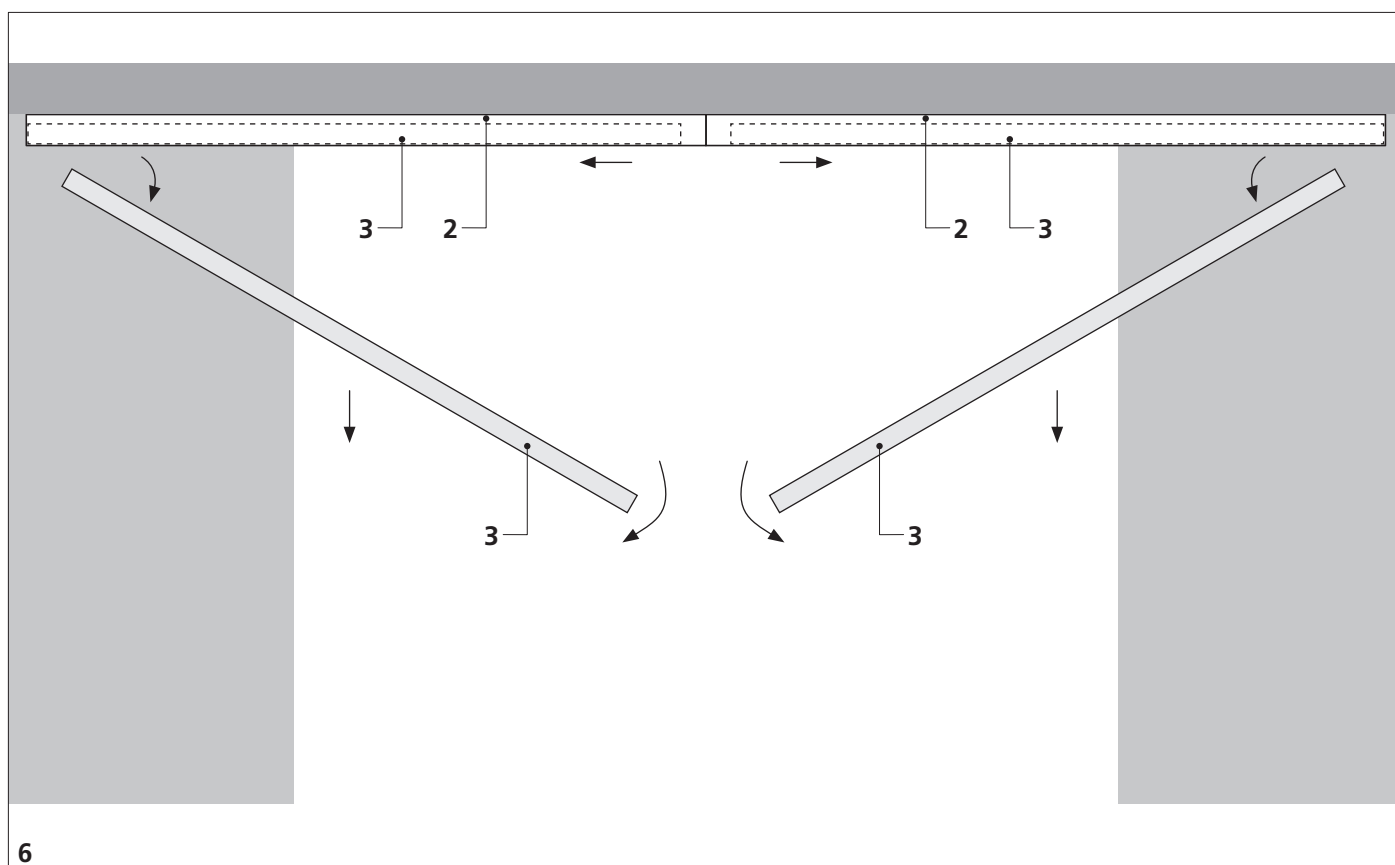

6. Togliere i binari effettuando i movimenti inversi rispetto a quanto fatto per il montaggio.
 6. Remove the rails doing the opposite steps done to put them on.

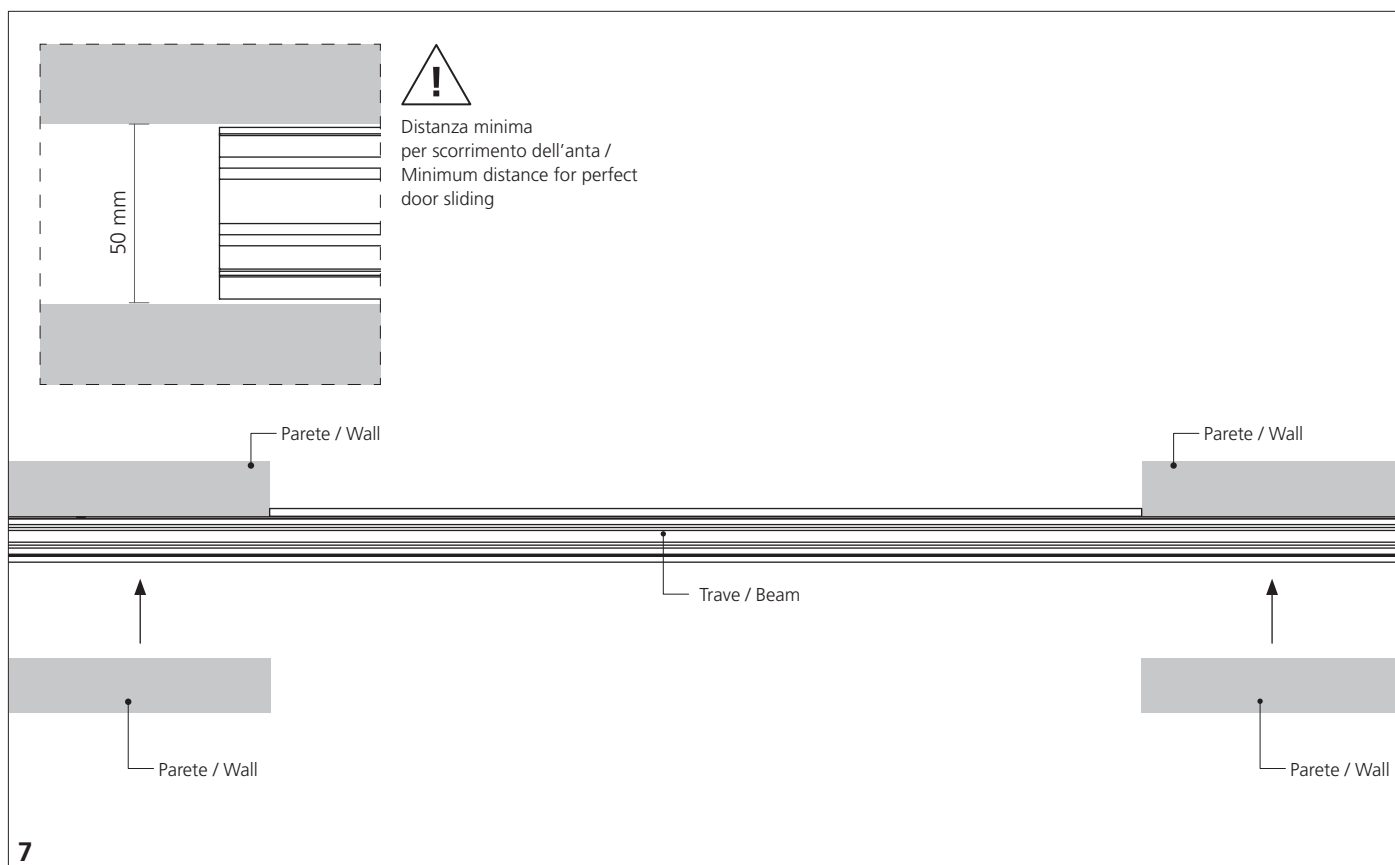

7. Chiudere il vano in corrispondenza della porta.
 7. Close the opening in correspondence of the door.

Pocket

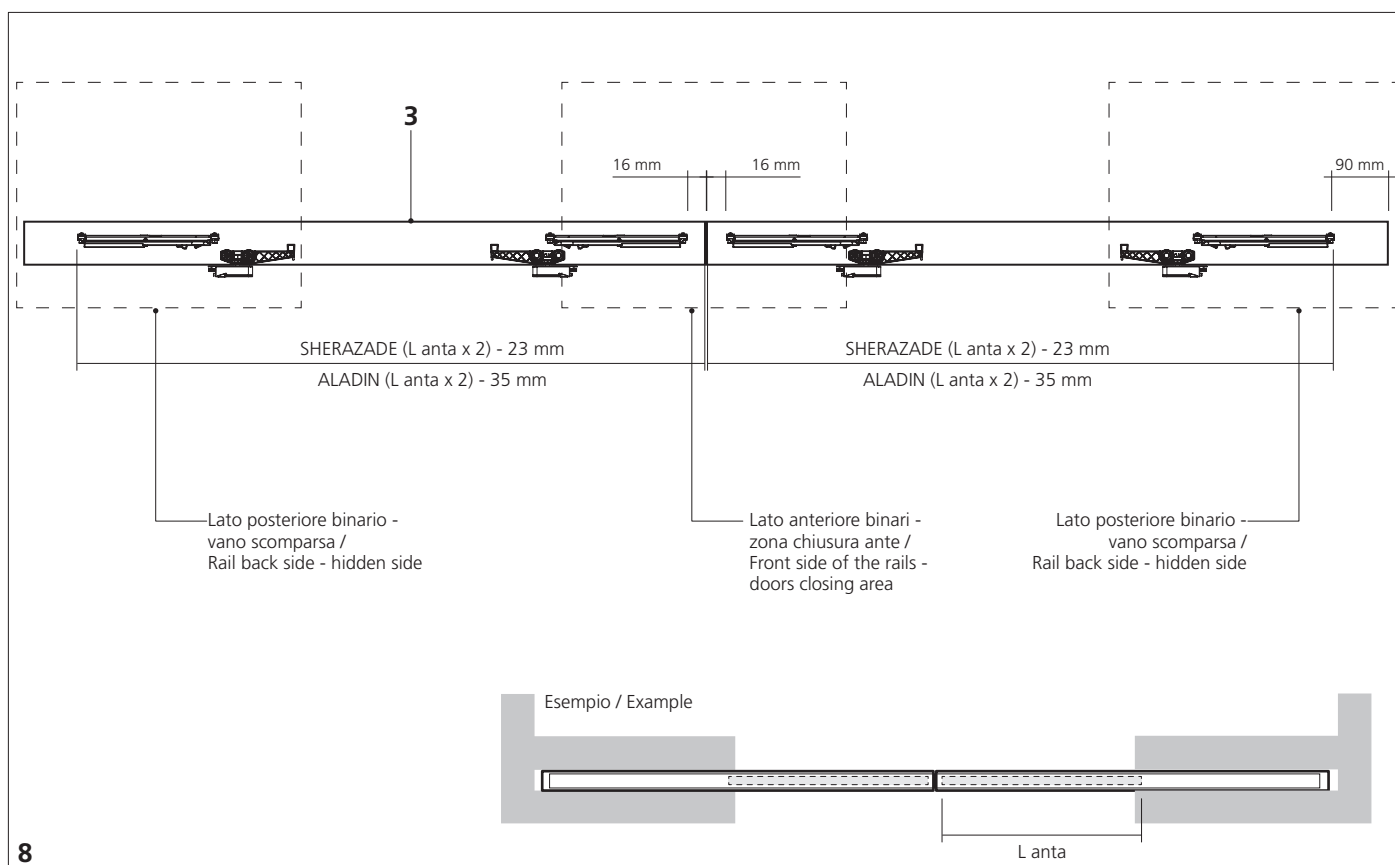

8

8. Posizionare i rallentatori alle distanze indicate dalle estremità dei binari.
8. Place the soft close mechanism at the right distances from the rails edges.

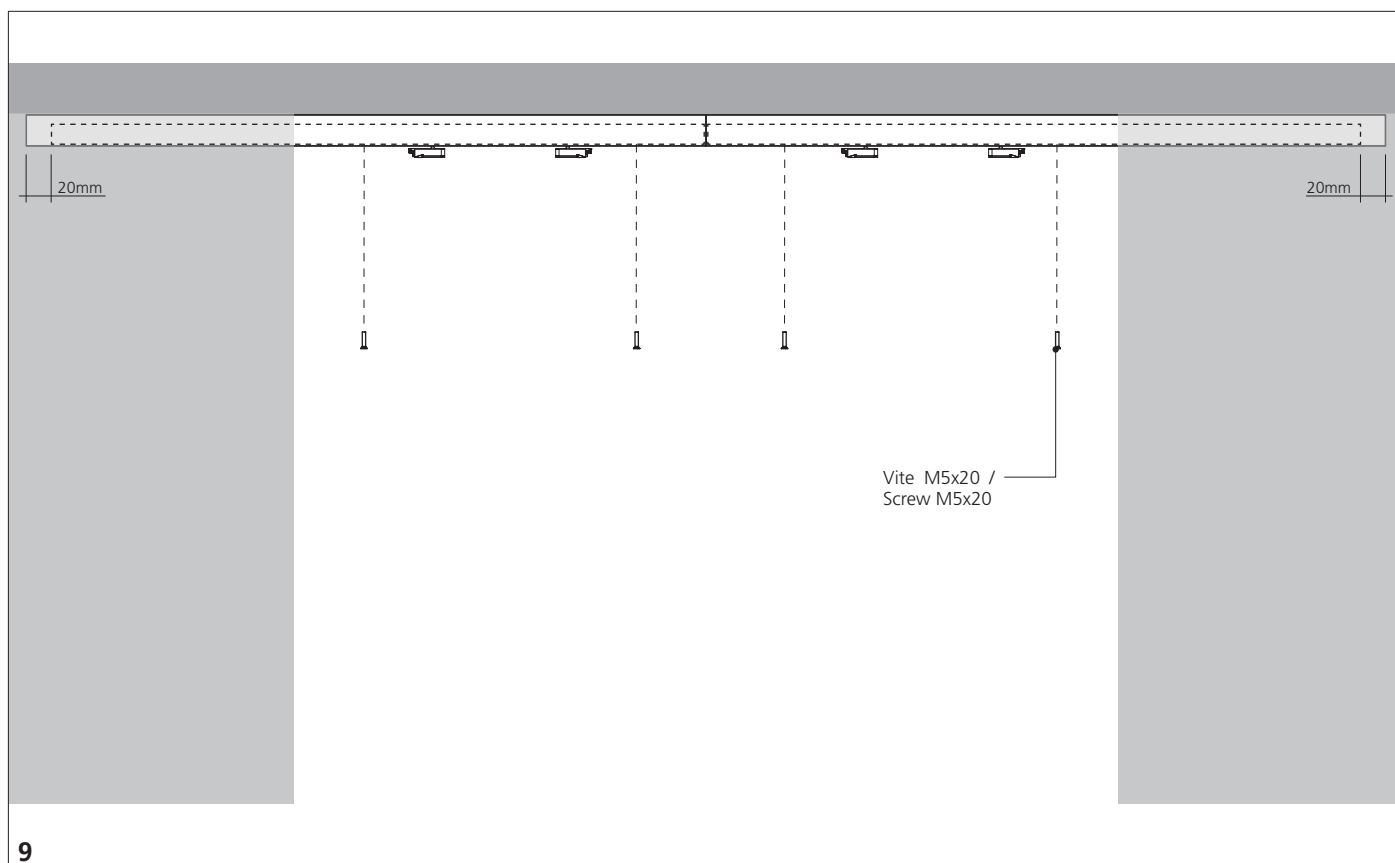

9

9. Rimontare i binari in posizione e inserire le viti di sicurezza nella parte a vista dei binari.
9. Install back the rails in position and install the safety screws in the visible part of the rails.

Pocket

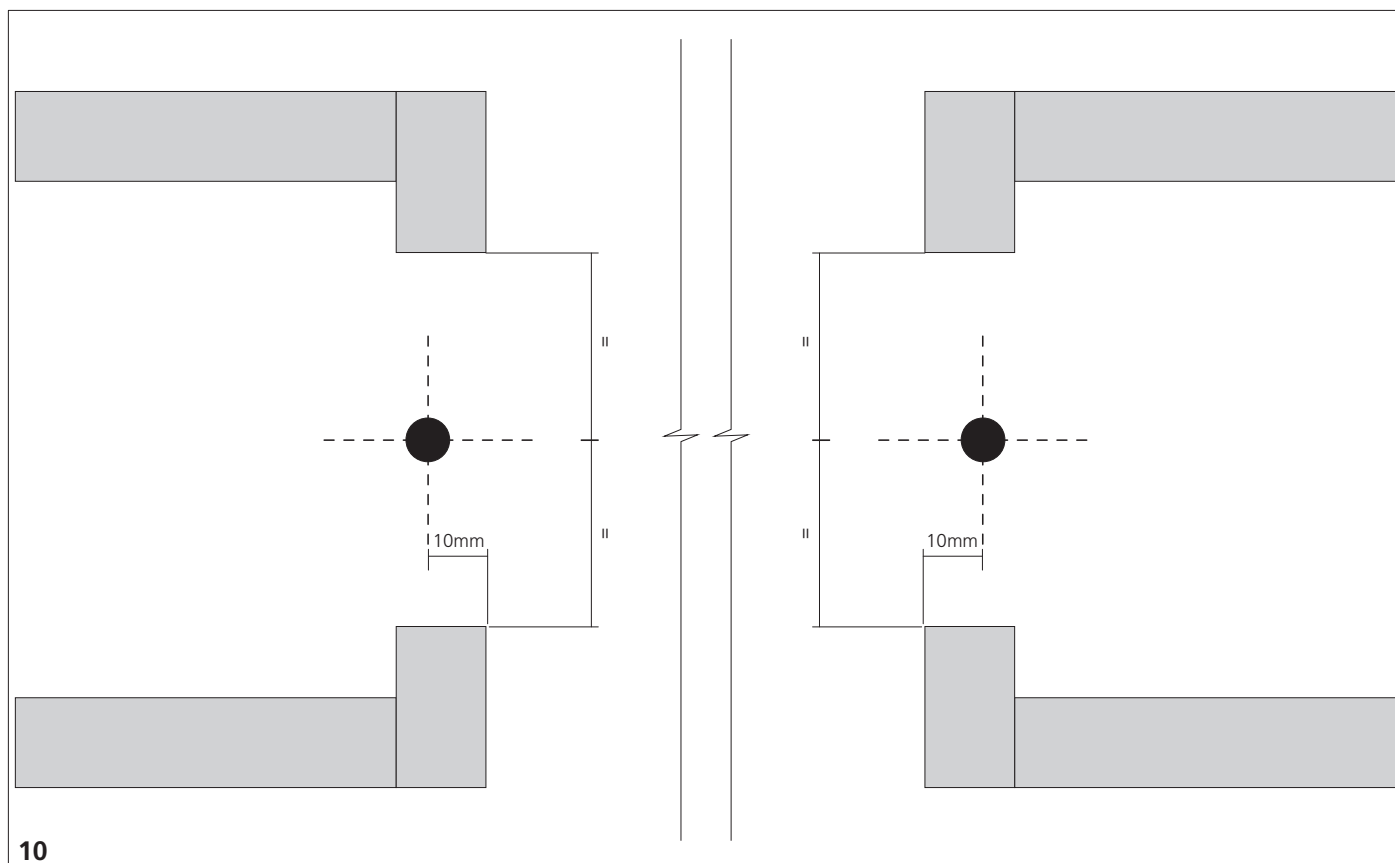

10. I perni devono essere posizionati in centro alle ante ed a 10 mm dal bordo della parete.
 10. The floor pivots have to be placed in the middle of the doors and at 10mm from the wall edges.

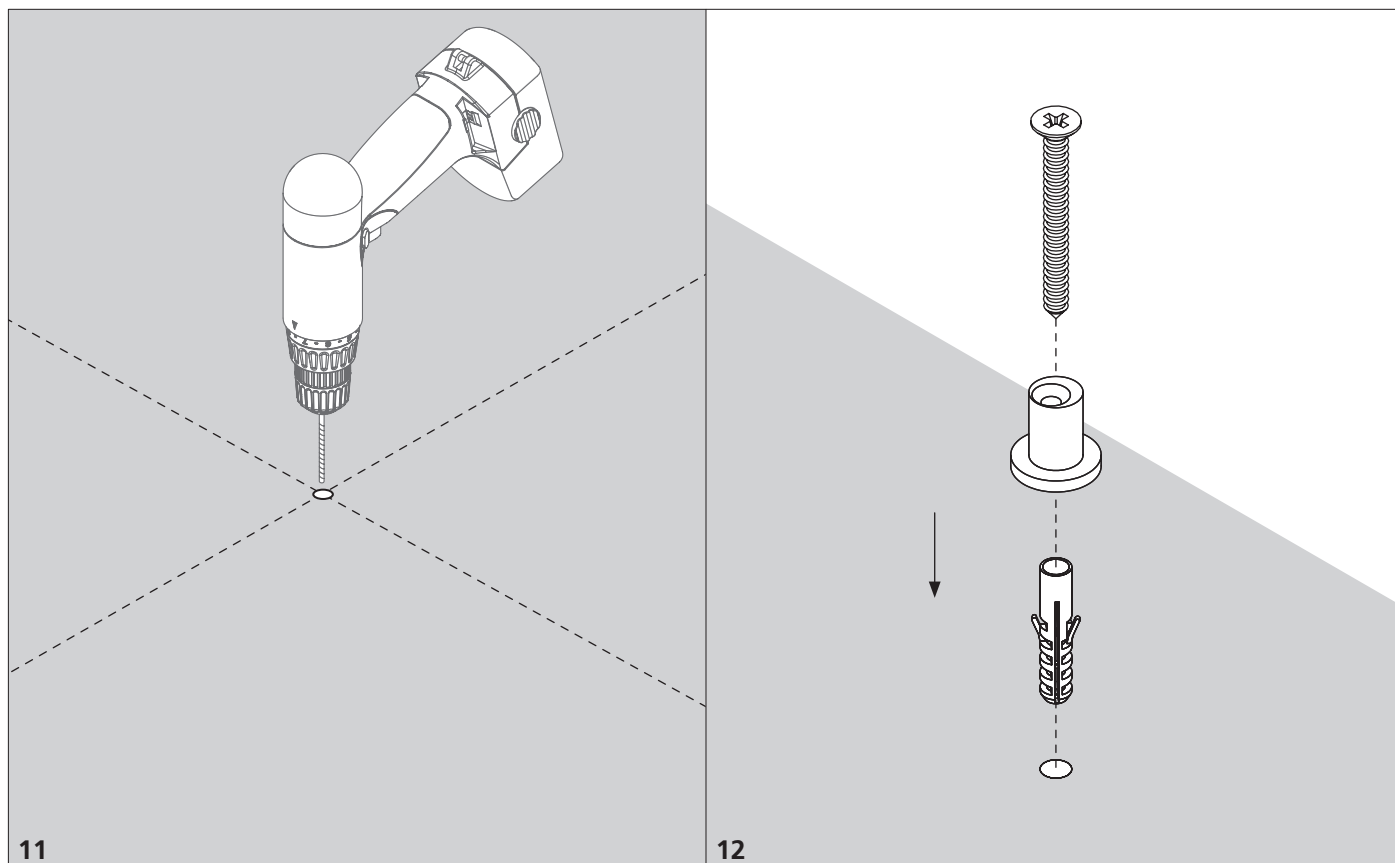

11. Forare nel punto prestabilito. / 12. Fissare i perni a pavimento.
 11. Drill the floor in predetermined point. / 12. Fix the pins to the floor.

Pocket

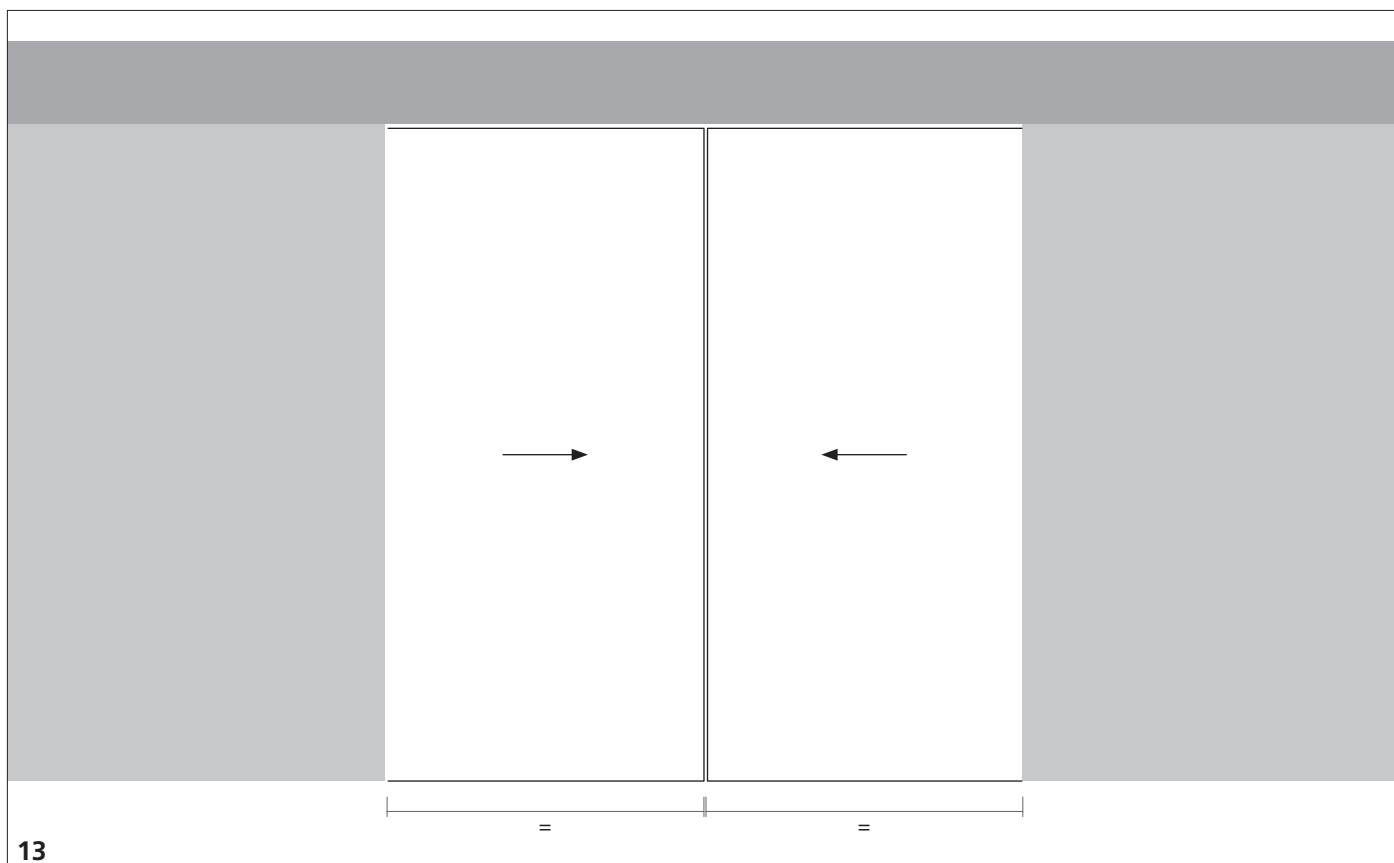

13. Installare le ante come descritto nelle pagine da 1.14 a 1.129. Verificare la perfetta chiusura delle ante nella mezzera del vano.
13. Install the doors as shown on pages from 1.14 a 1.129. Check the perfect closure of the doors in the opening centerline.