



SHERAZADE

Esempio di configurazione / Configuration examples	pag.	12.2.102
Abaco componenti / Components list	pag.	12.2.105
Montaggio versione A / Version A installation	pag.	12.2.106
Montaggio versione B / Version B installation	pag.	12.2.110
Montaggio versione C / Version C installation	pag.	12.2.114

Informazioni pre-montaggio versione A / Version A pre-installation information

ATTENZIONE: il numero dei pannelli rappresentati nello schema è puramente esemplificativo. Fare sempre riferimento ai disegni di progetto allegati. / WARNING: the number of panels represented in the diagram is purely illustrative. Always refer to the attached design drawings.

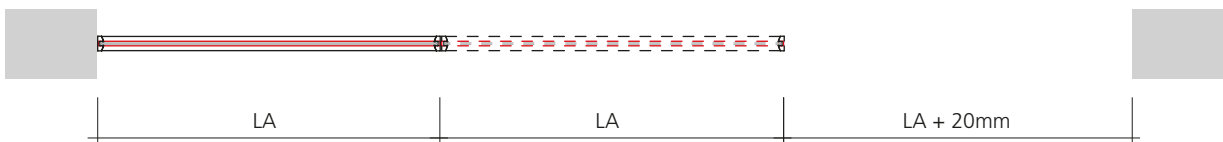
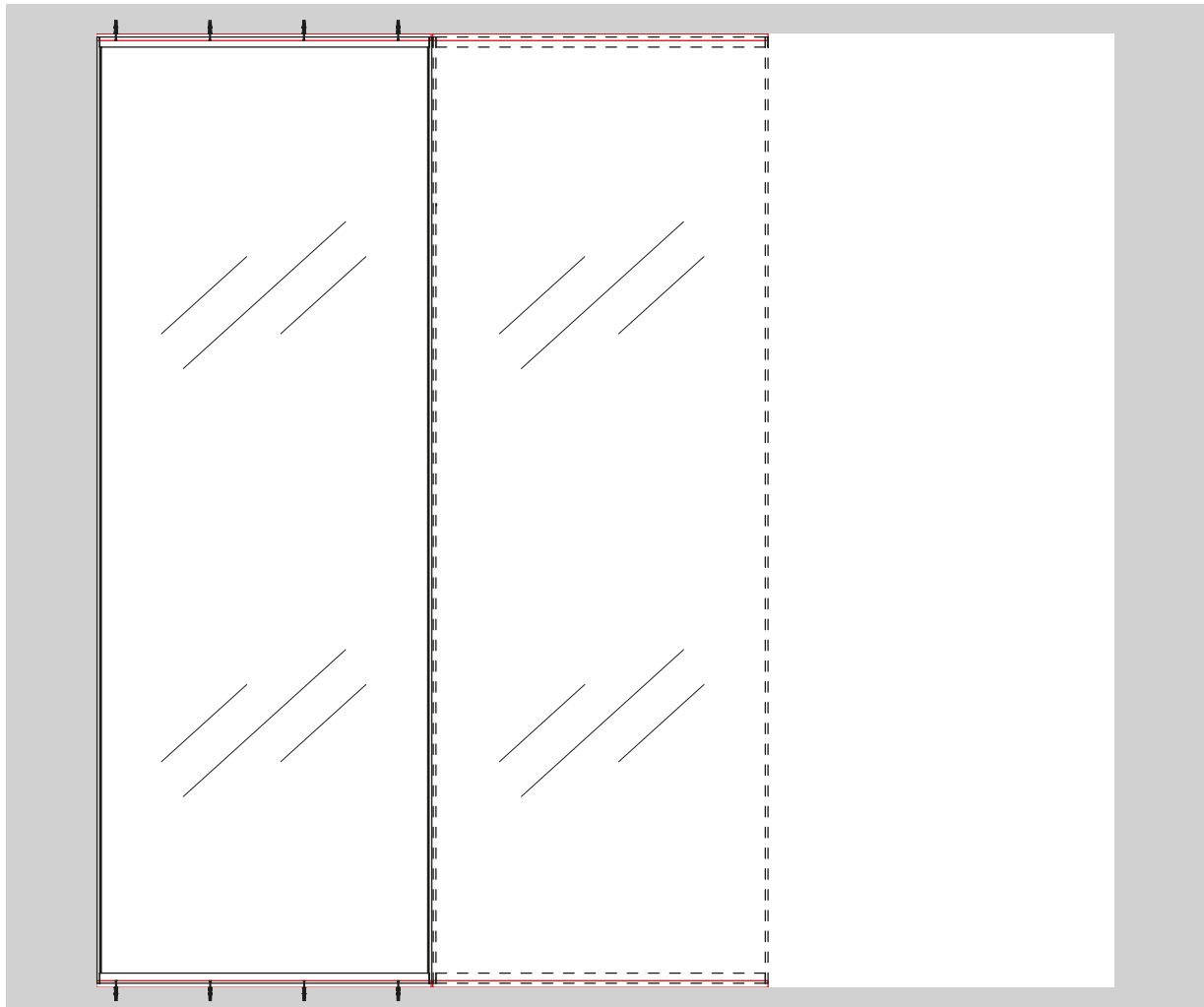

Distanza minima per poter  
inserire l'anta /  
Minimum width in order to  
insert the door

Informazioni pre-montaggio versione B / Version B pre-installation information

**ATTENZIONE:** il numero dei pannelli rappresentati nello schema è puramente esemplificativo. Fare sempre riferimento ai disegni di progetto allegati. / **WARNING:** the number of panels represented in the diagram is purely illustrative. Always refer to the attached design drawings.

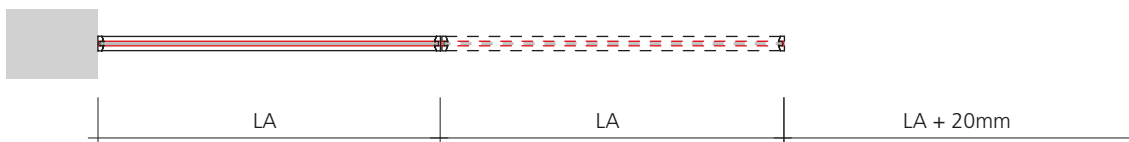
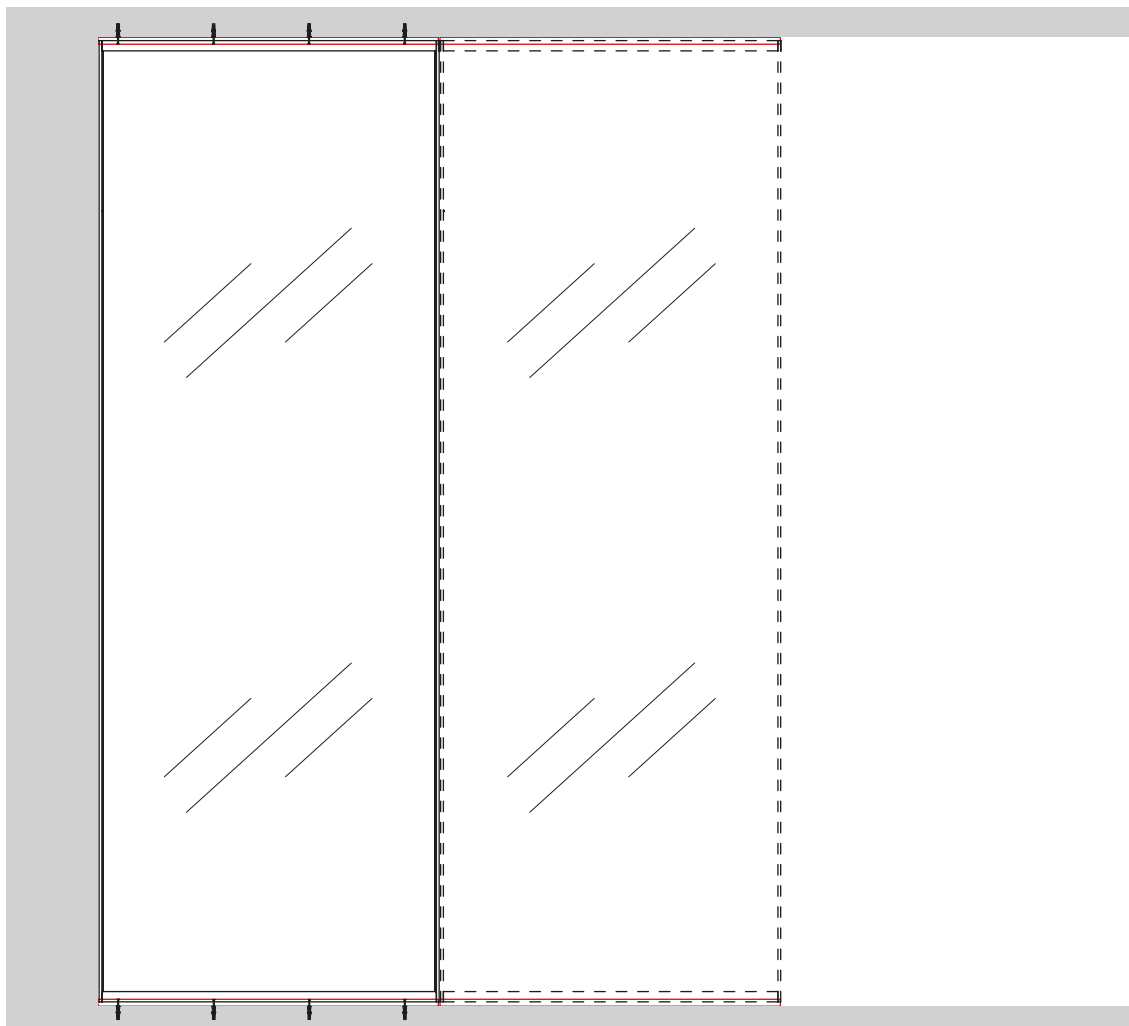

Distanza minima per poter  
inserire l'anta /  
Minimum width in order to  
insert the door

Informazioni pre-montaggio versione C / Version C pre-installation information

ATTENZIONE: il numero dei pannelli rappresentati nello schema è puramente esemplificativo. Fare sempre riferimento ai disegni di progetto allegati. / WARNING: the number of panels represented in the diagram is purely illustrative. Always refer to the attached design drawings.

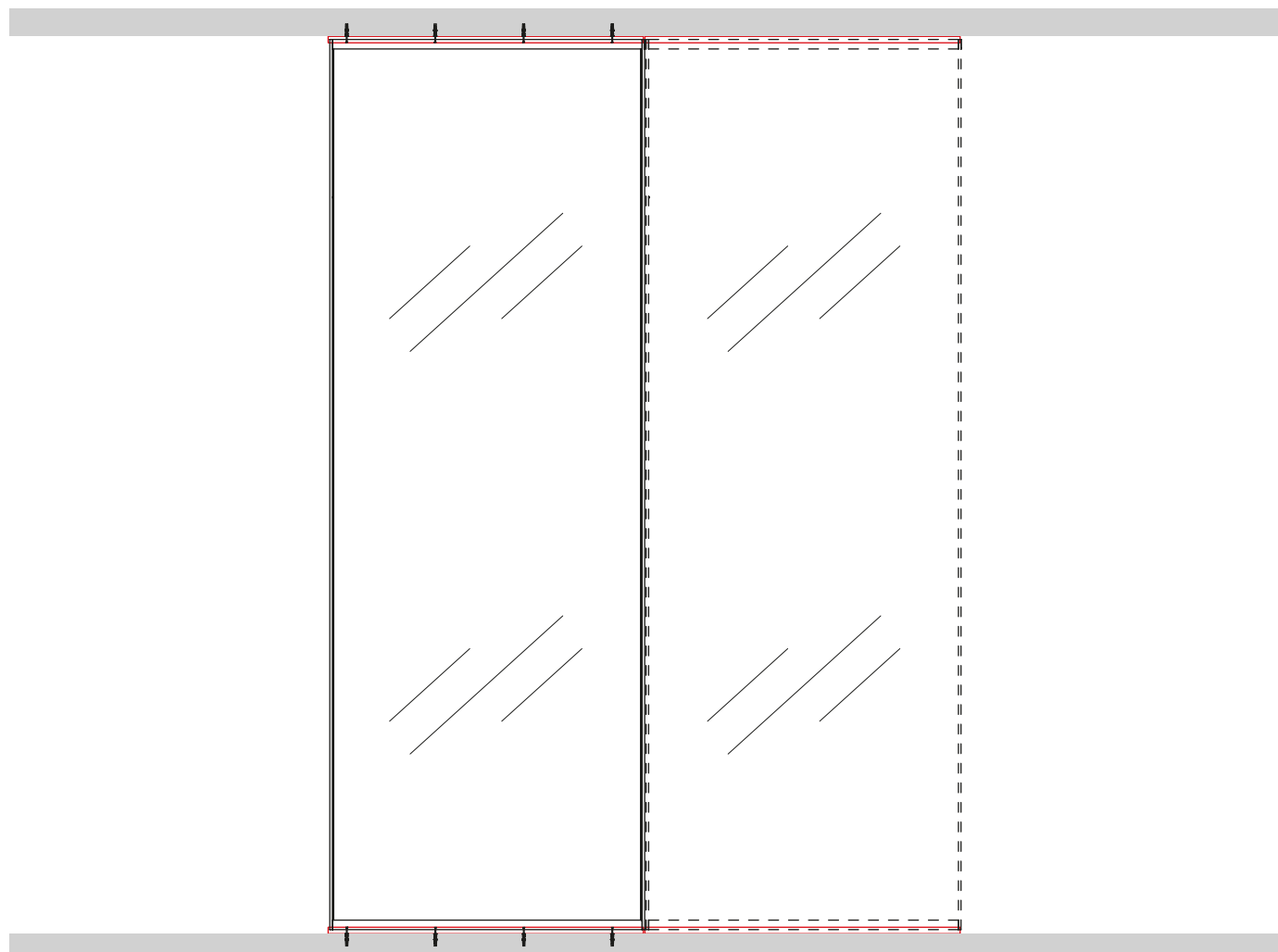

LA + 20mm

LA

LA

LA + 20mm

Distanza minima per poter  
inserire l'anta /  
Minimum width in order to  
insert the door

Distanza minima per poter  
inserire l'anta /  
Minimum width in order to  
insert the door

1. Profilo a soffitto per anta fissa / Ceiling profile for fixed door
2. Profilo a terra per anta fissa / Floor profile for fixed door

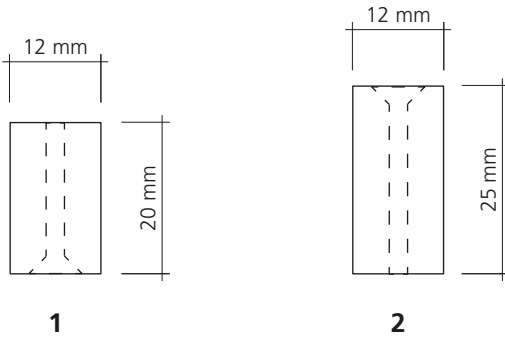

**ATTENZIONE:** Prima di proseguire con il montaggio, leggere attentamente tutto il fascicolo delle istruzioni. /  
**ATTENTION:** Before proceeding with the installation, read carefully all the installation manual.

**Simbologia e strumenti di montaggio/ Icons and assembly tools**



Fare attenzione/  
Pay attention



Allineare/  
Align

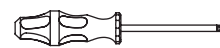

Cacciavite a croce/  
Crosshead screwdriver



Avvicinare - togliere/  
Bring closer - Remove



Avvitare-regolare/  
Screw-adjust



Chiave a brugola/  
Allen key



In squadra/  
At right angle



Inserisci/  
Insert



Quota/  
Level

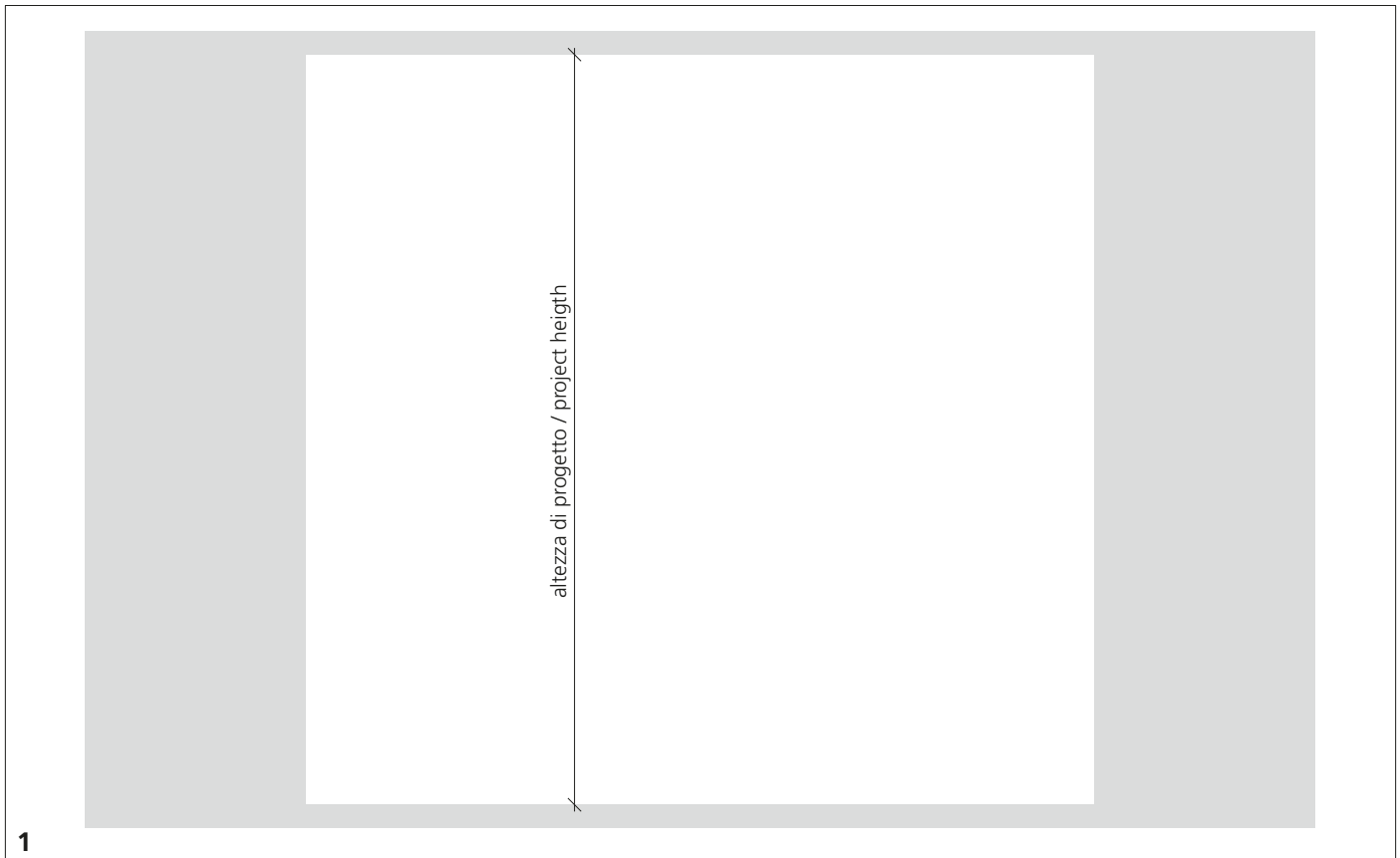

1. Rilevare le misure del vano e confrontarle con quelle riportate sul disegno di progetto allegato.
1. Check the measurements of the compartment and compare them with those reported on the drawing indications attached.

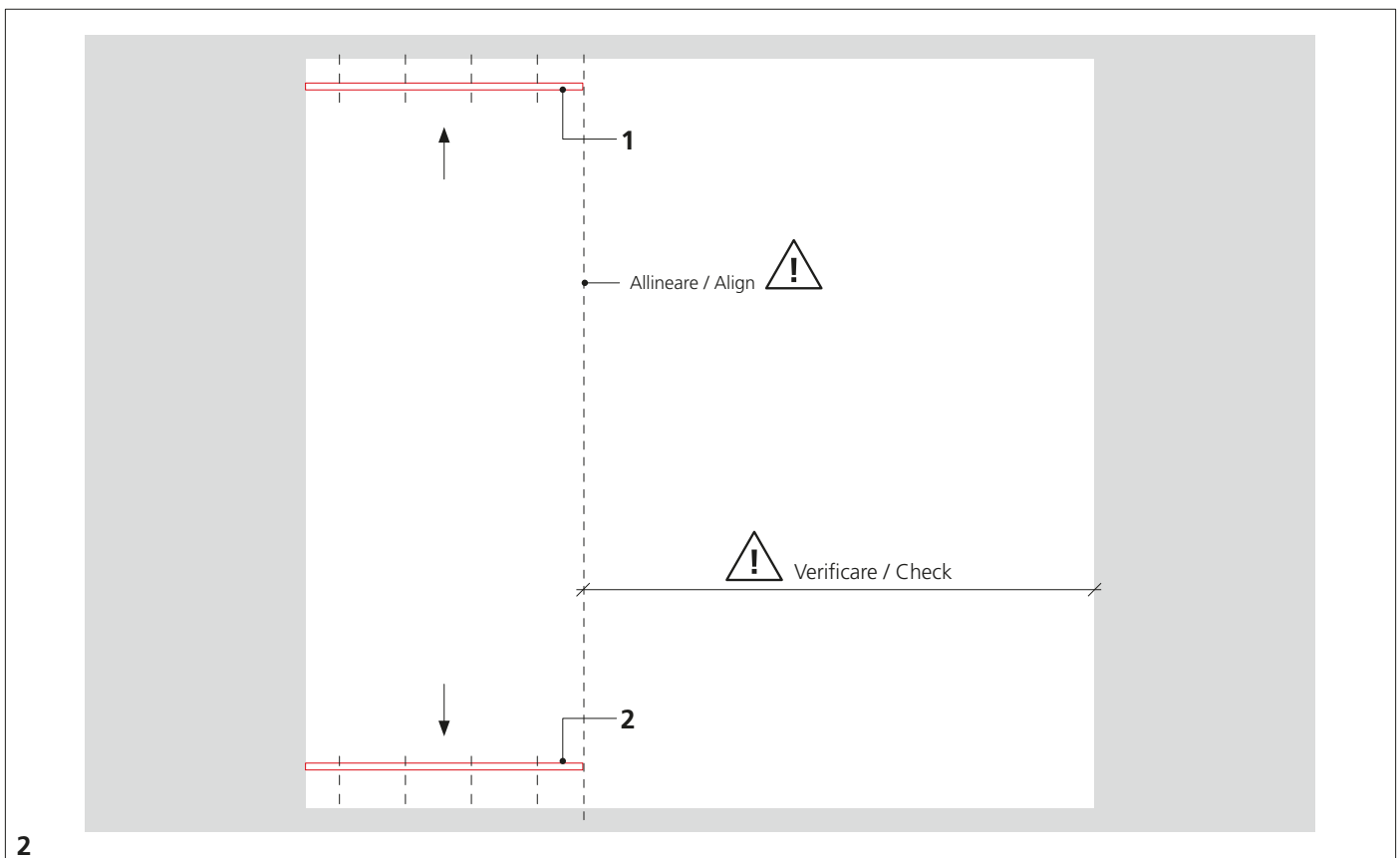

2. Fissare il profilo a soffitto ed il profilo a pavimento. Verificare la distanza laterale per l'inserimento delle ante.
2. Fix the profile to the floor and to the ceiling. Check the lateral distance to insert the doors.

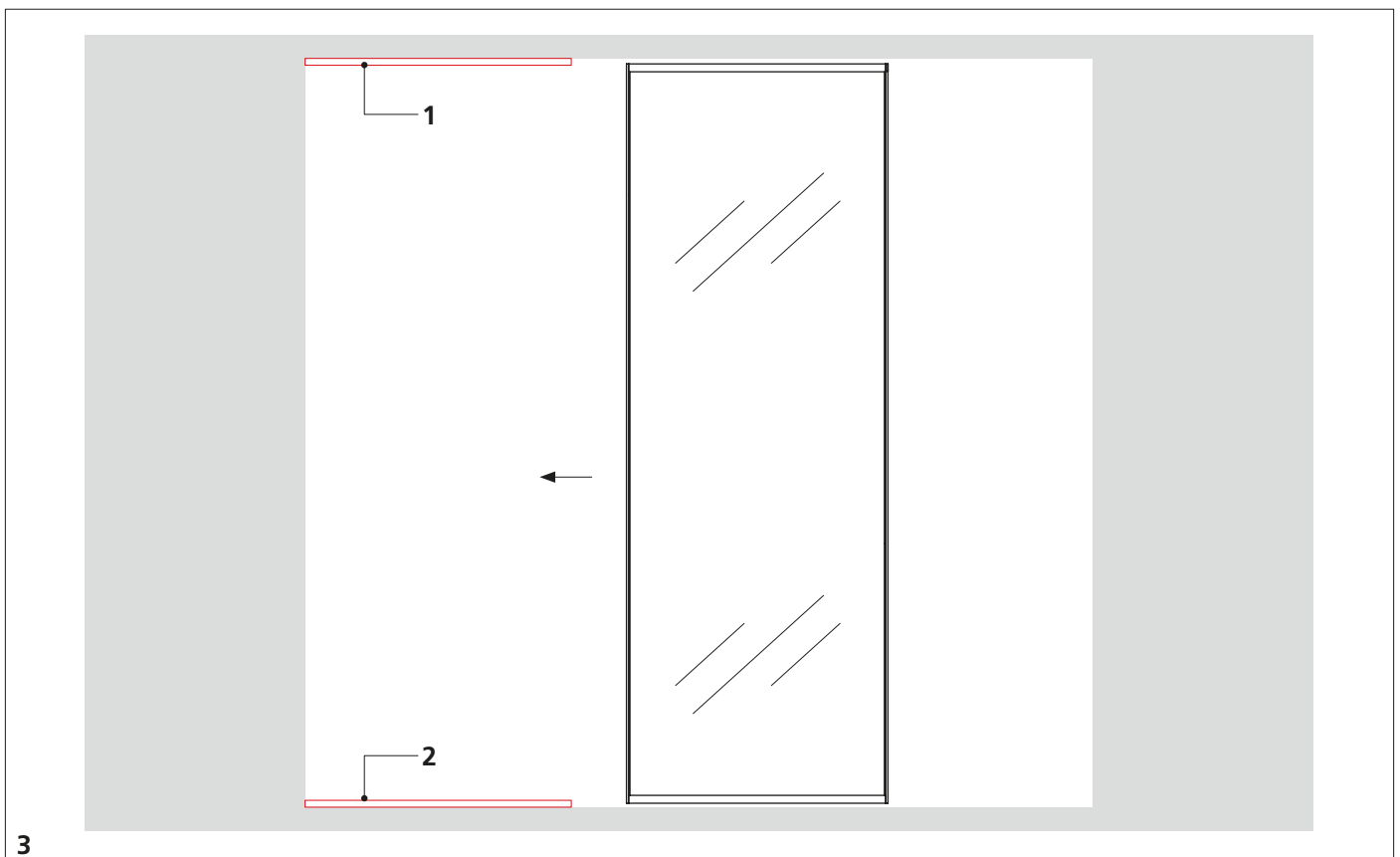
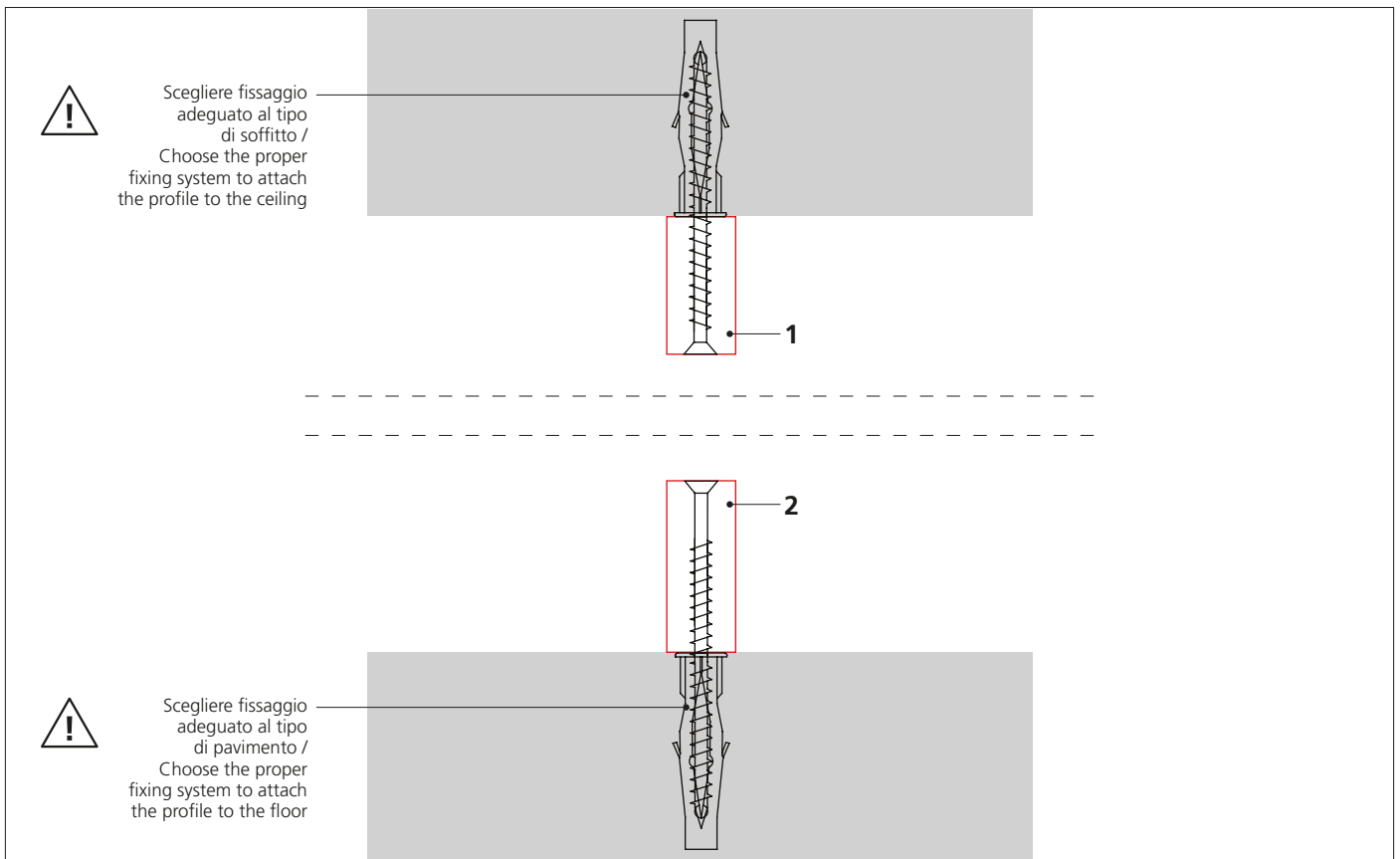

**3. Infilare l'anta nei profili.**  
**3. Let the door slip into the profiles.**



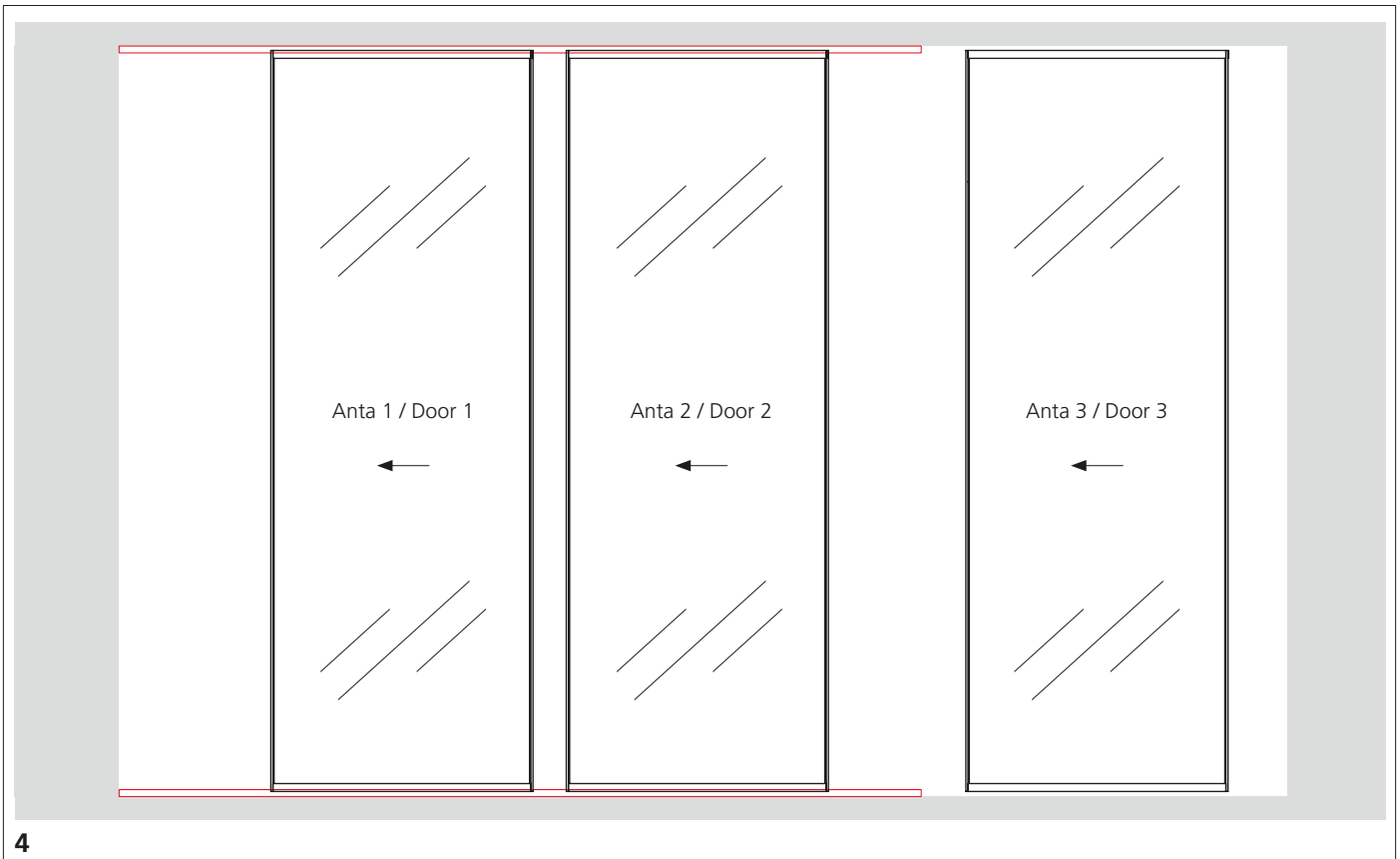

4. In caso di composizione con più ante, seguire la numerazione delle ante presente sui disegni di progetto.  
4. In case of composition with several doors, follow the numbering of the doors on the design drawings.

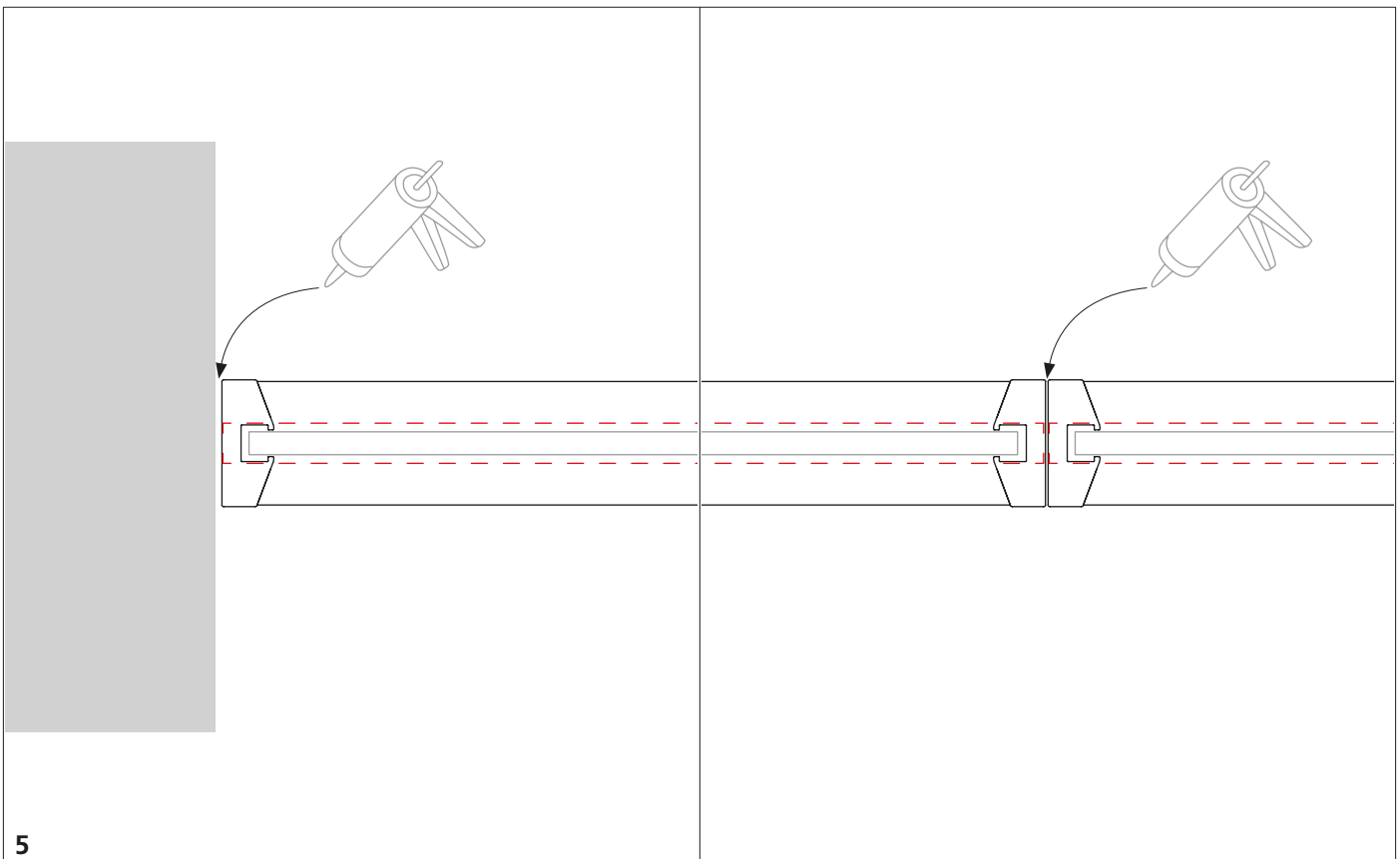

5. Fissare la prima anta a parete con silicone neutro. In caso di più ante usare il silicone anche tra le ante successive.  
5. Fix the first door to the wall with the neutral silicone. In case of multiple doors use the silicone also between subsequent doors.

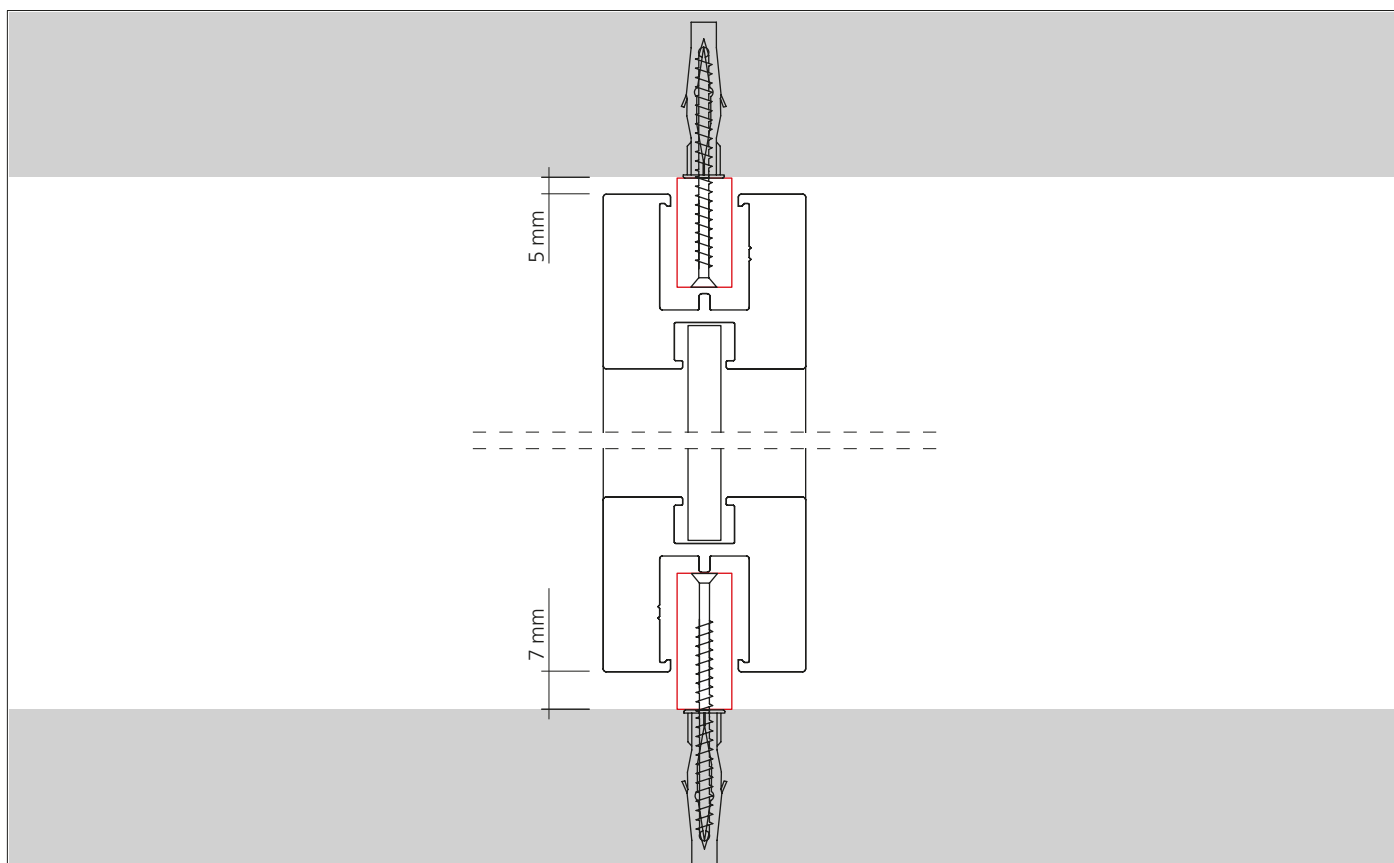

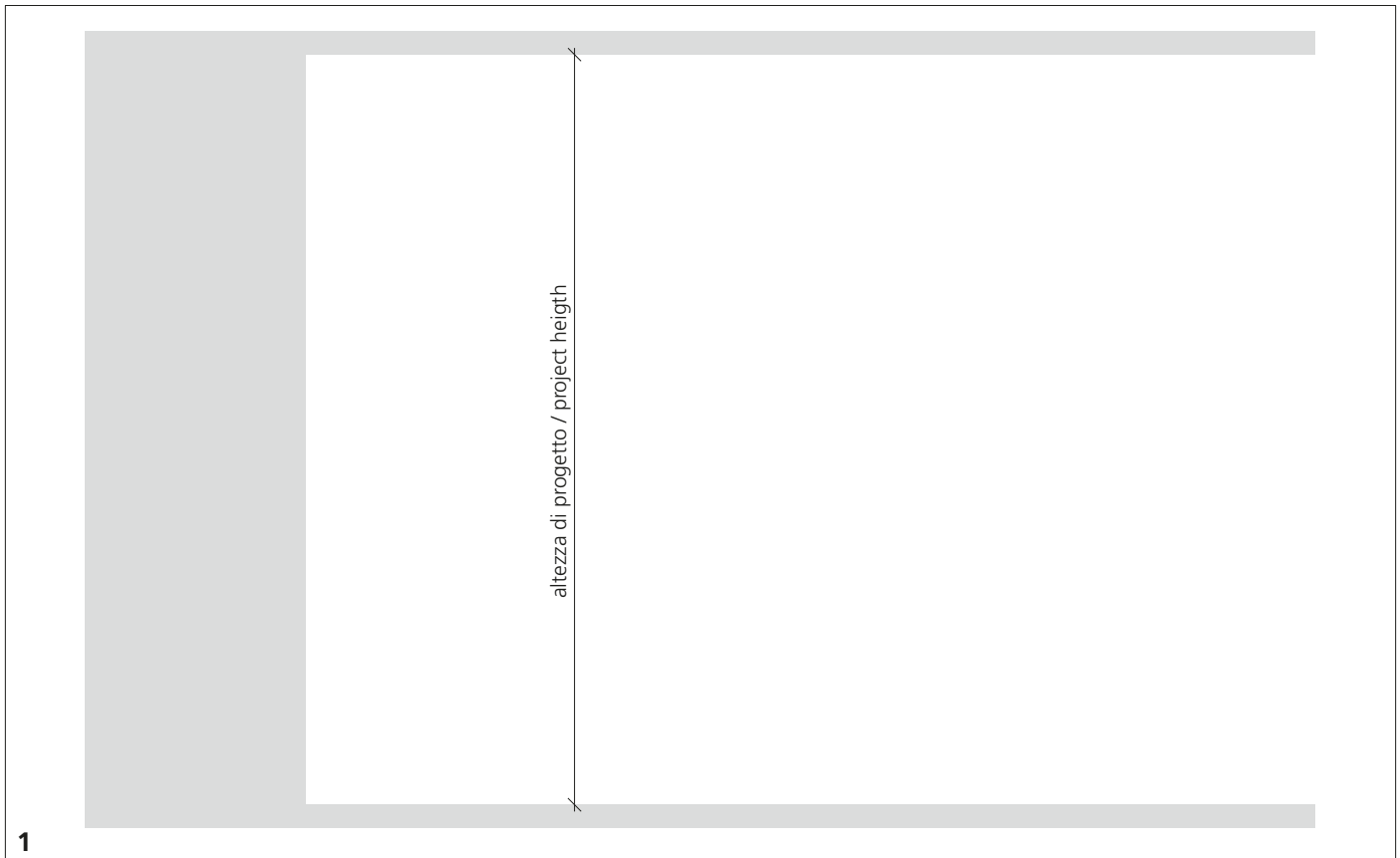

1. Rilevare le misure del vano e confrontarle con quelle riportate sul disegno di progetto allegato.
1. Check the measurements of the compartment and compare them with those reported on the drawing indications attached.

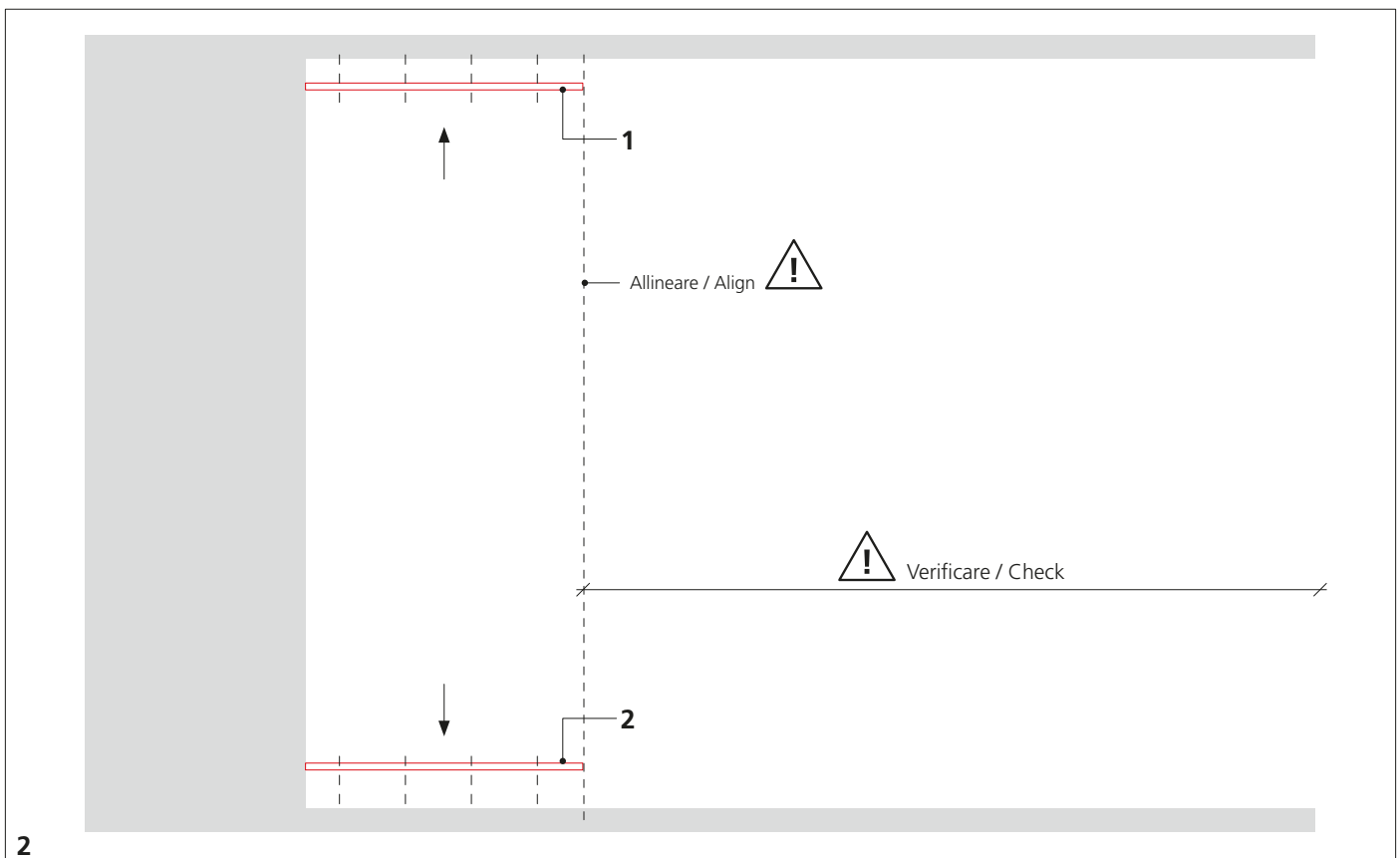

2. Fissare il profilo a soffitto ed il profilo a pavimento. Verificare la distanza laterale per infilare le ante.
2. Fix the profile to the floor and to the ceiling. Check the lateral distance to insert the doors.

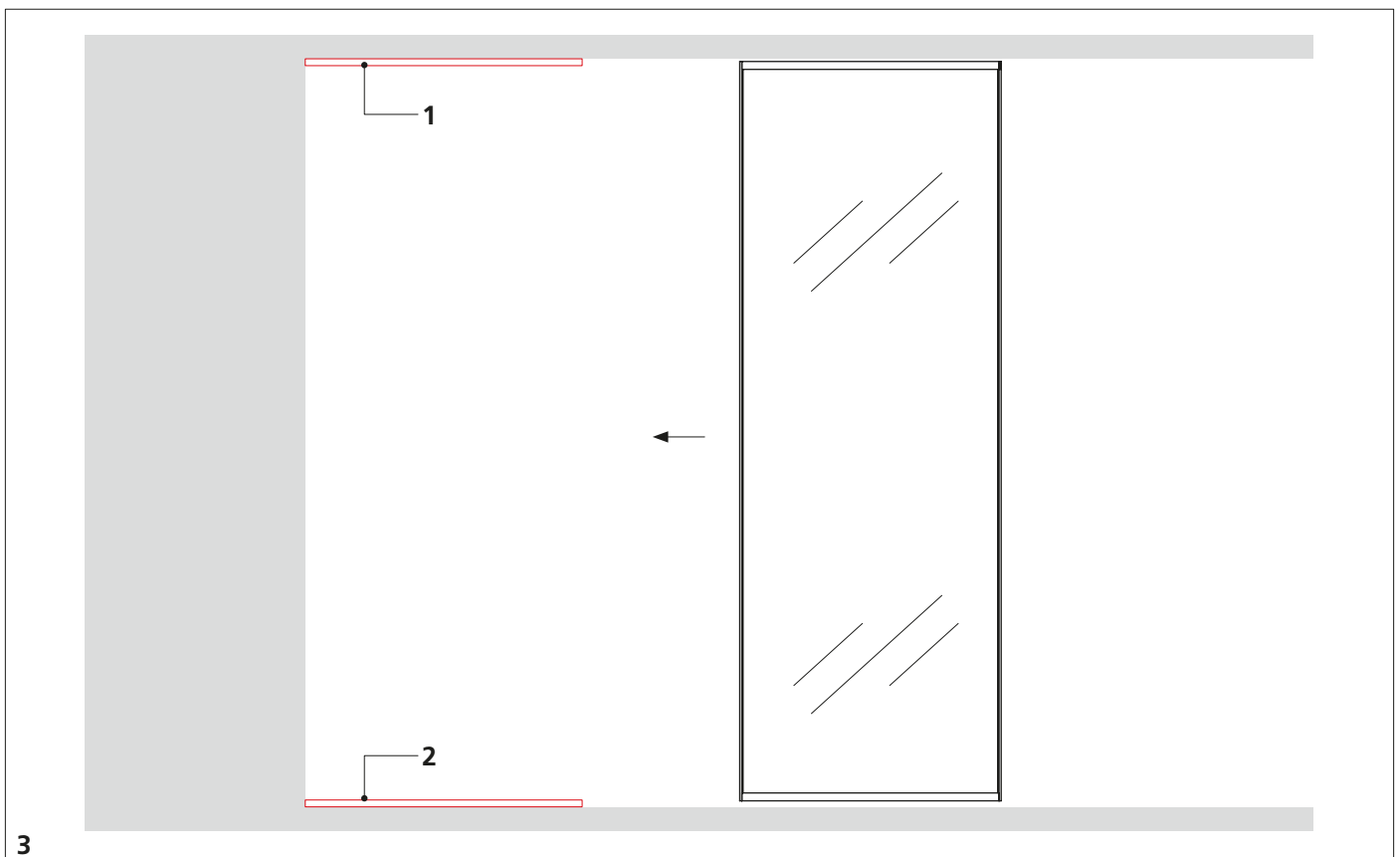
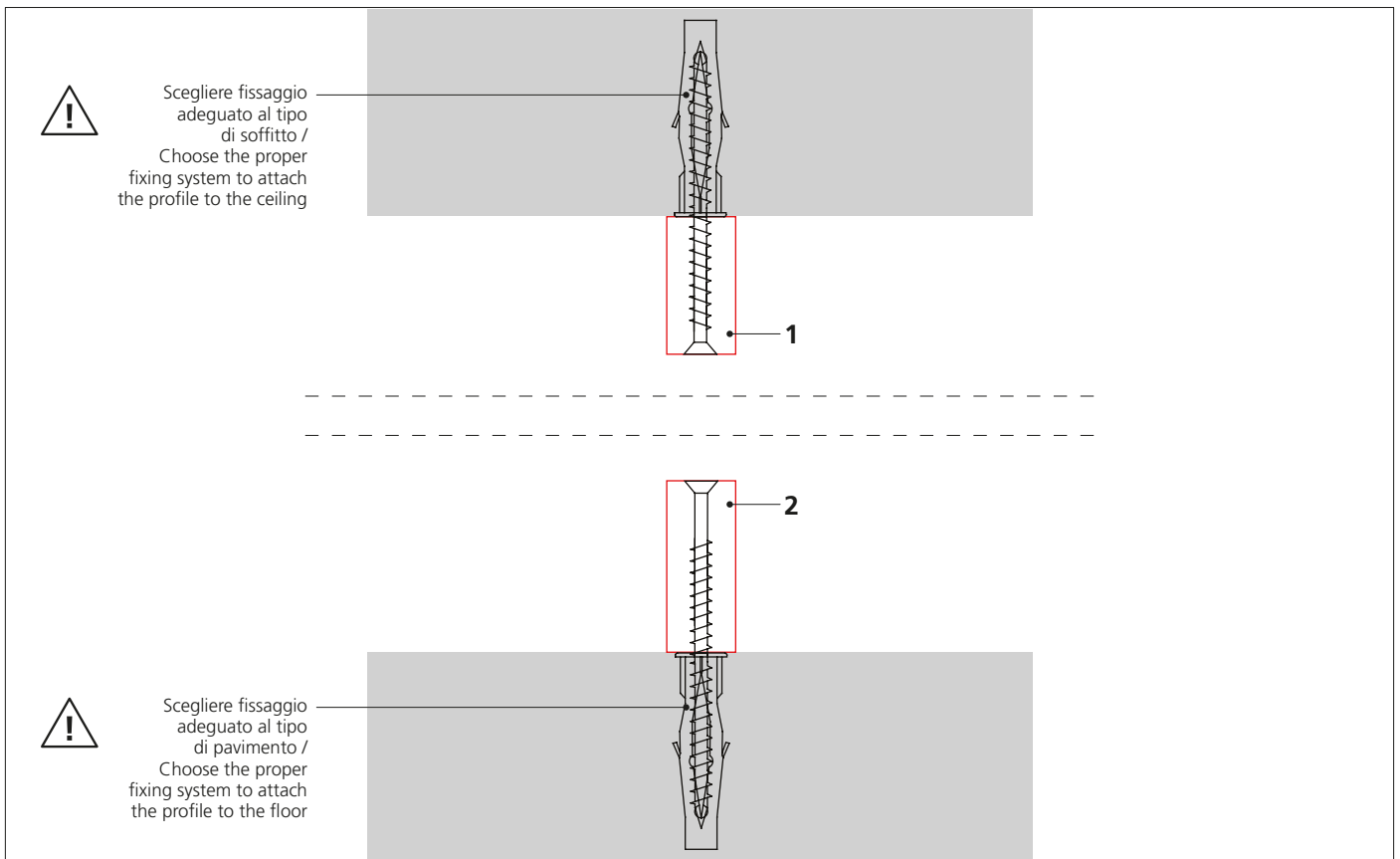

**3. Infilare l'anta nei profili.**  
**3. Let the door slip into the profiles.**

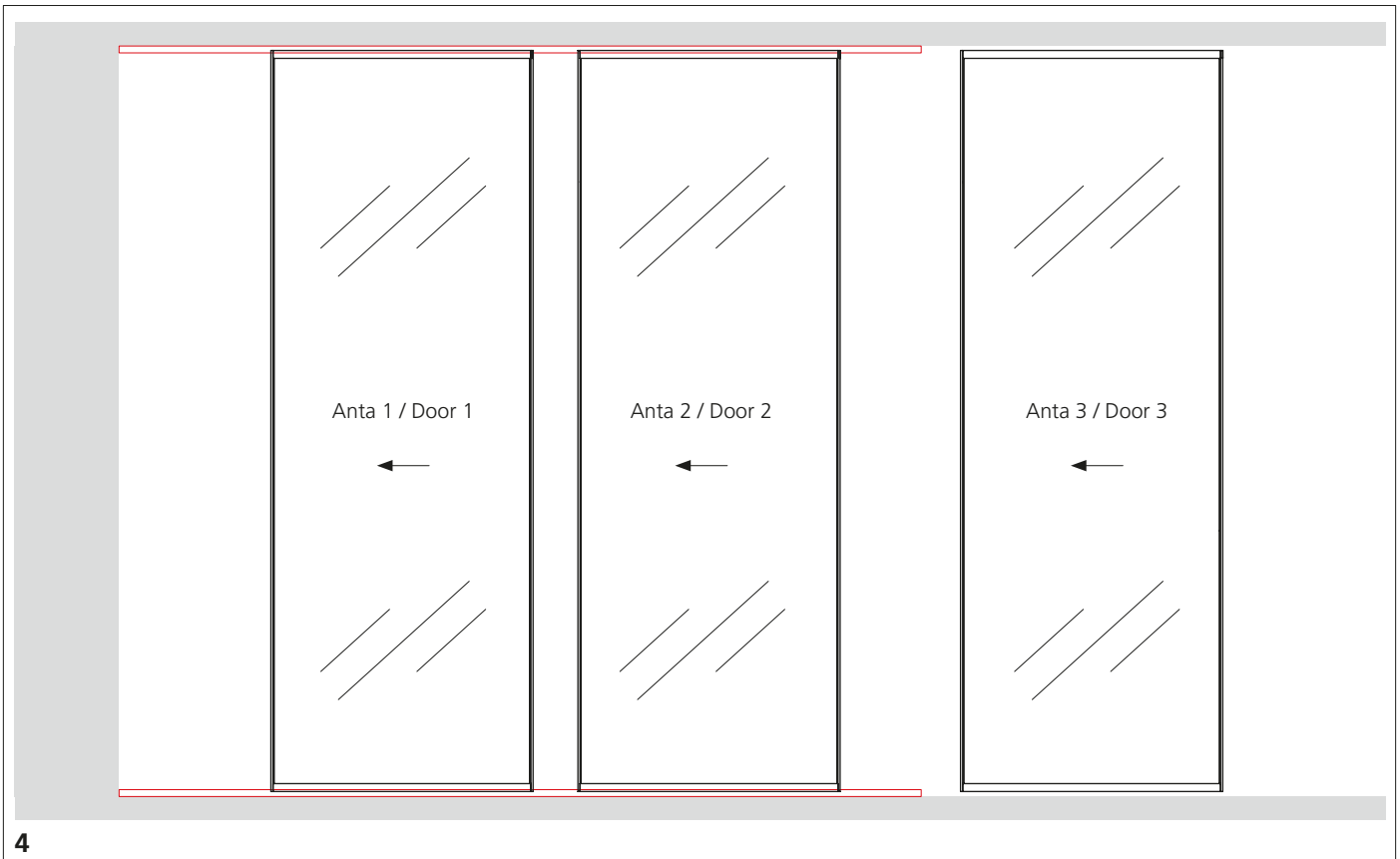

4

4. In caso di composizione con più ante, seguire la numerazione delle ante presente sui disegni di progetto.  
4. In case of composition with several doors, follow the numbering of the doors on the design drawings.

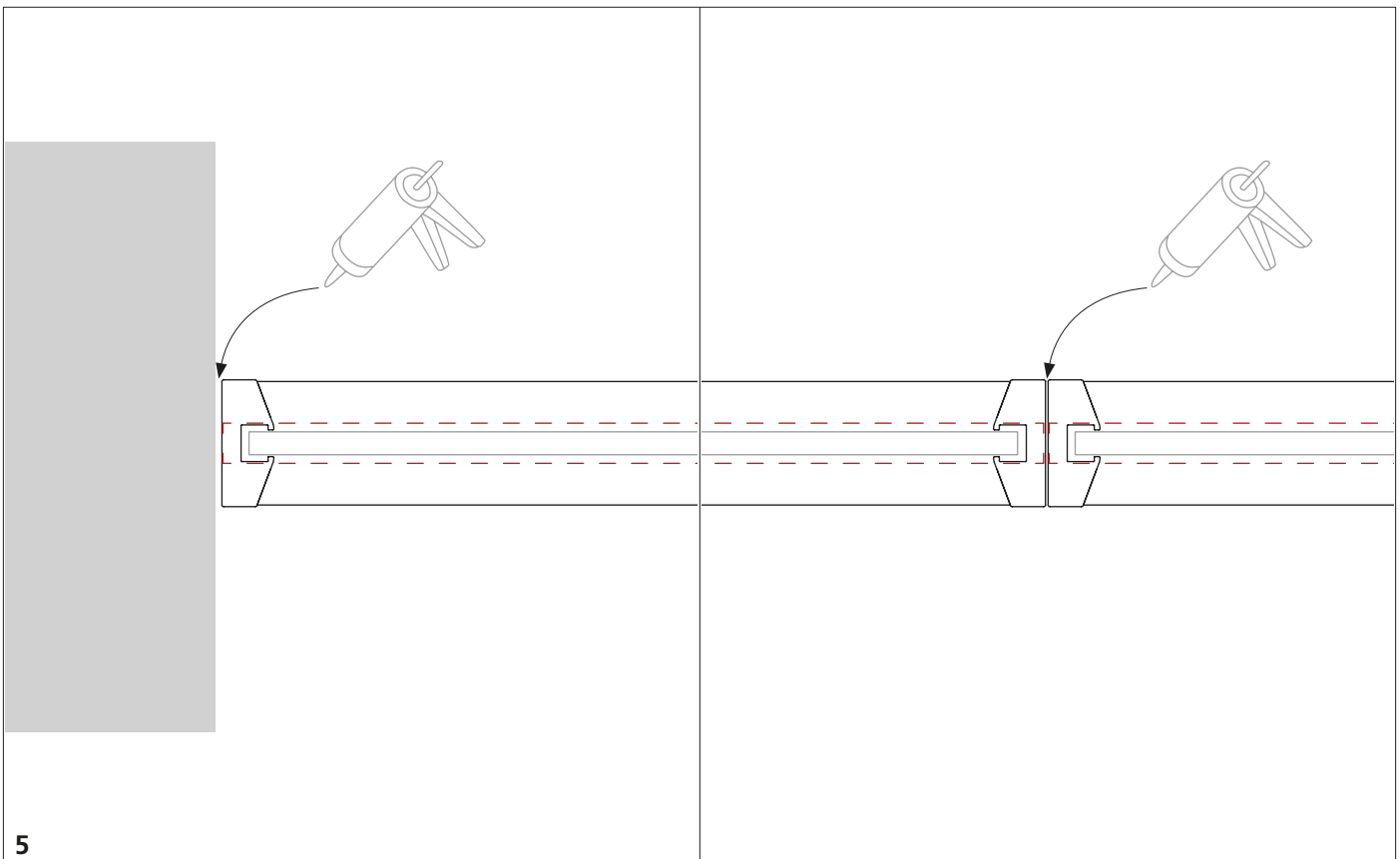

5

5. Fissare la prima anta a parete con silicone neutro. In caso di più ante usare il silicone anche tra le ante successive.  
5. Fix the first door to the wall with the neutral silicone. In case of multiple doors use the silicone also between subsequent doors.

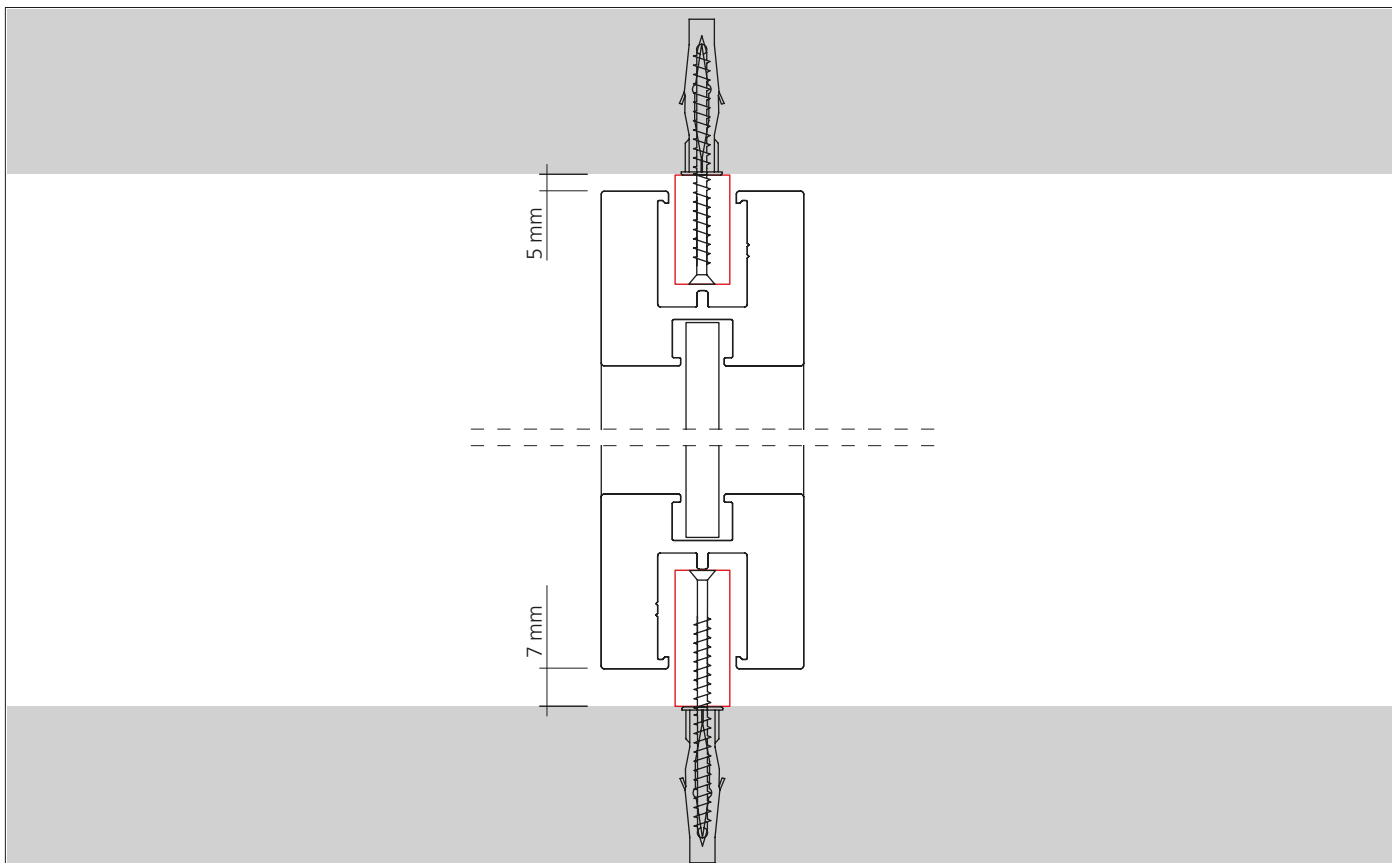

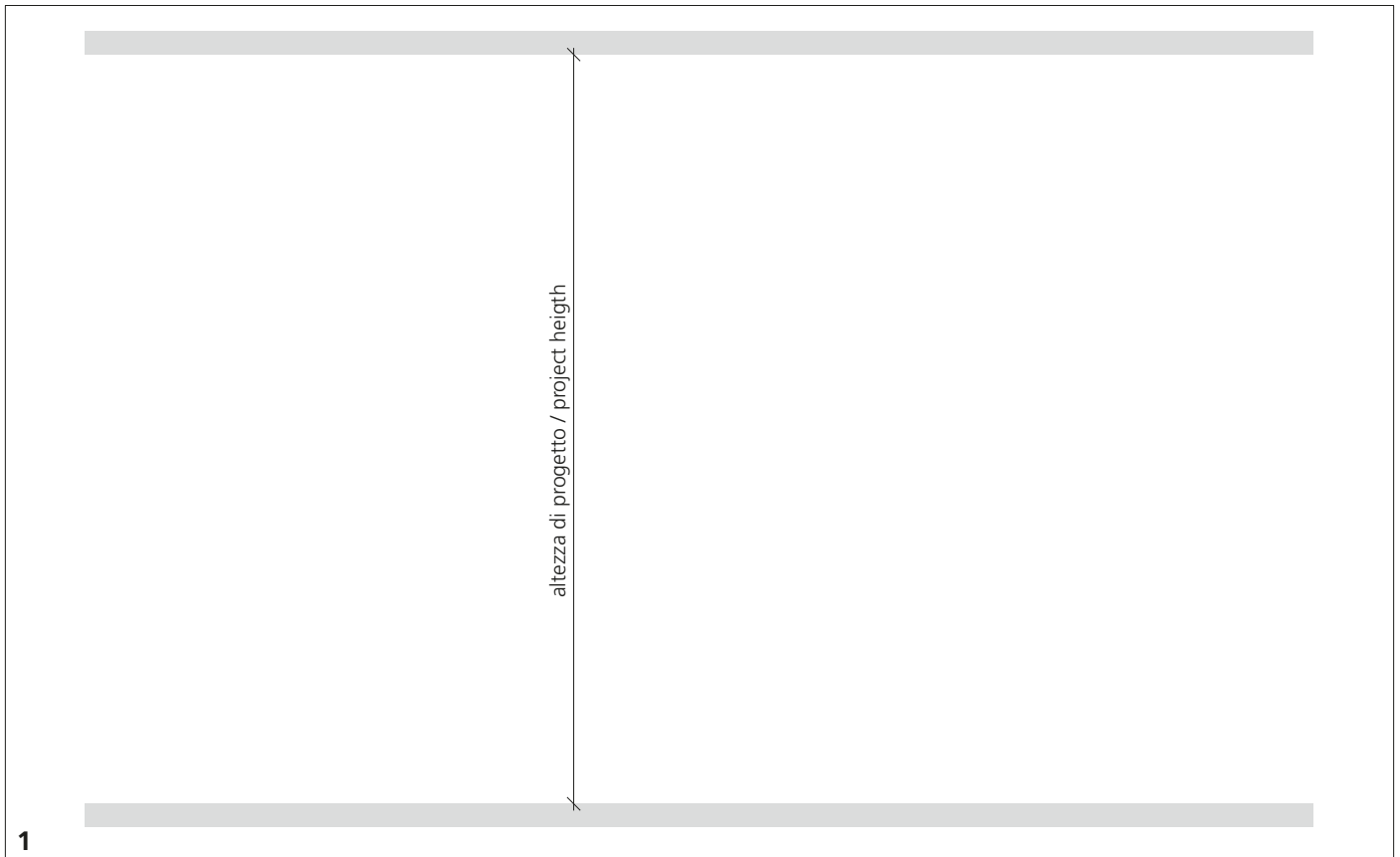

1. Rilevare le misure del vano e confrontarle con quelle riportate sul disegno di progetto allegato.  
1. Check the measurements of the compartment and compare them with those reported on the drawing indications attached.

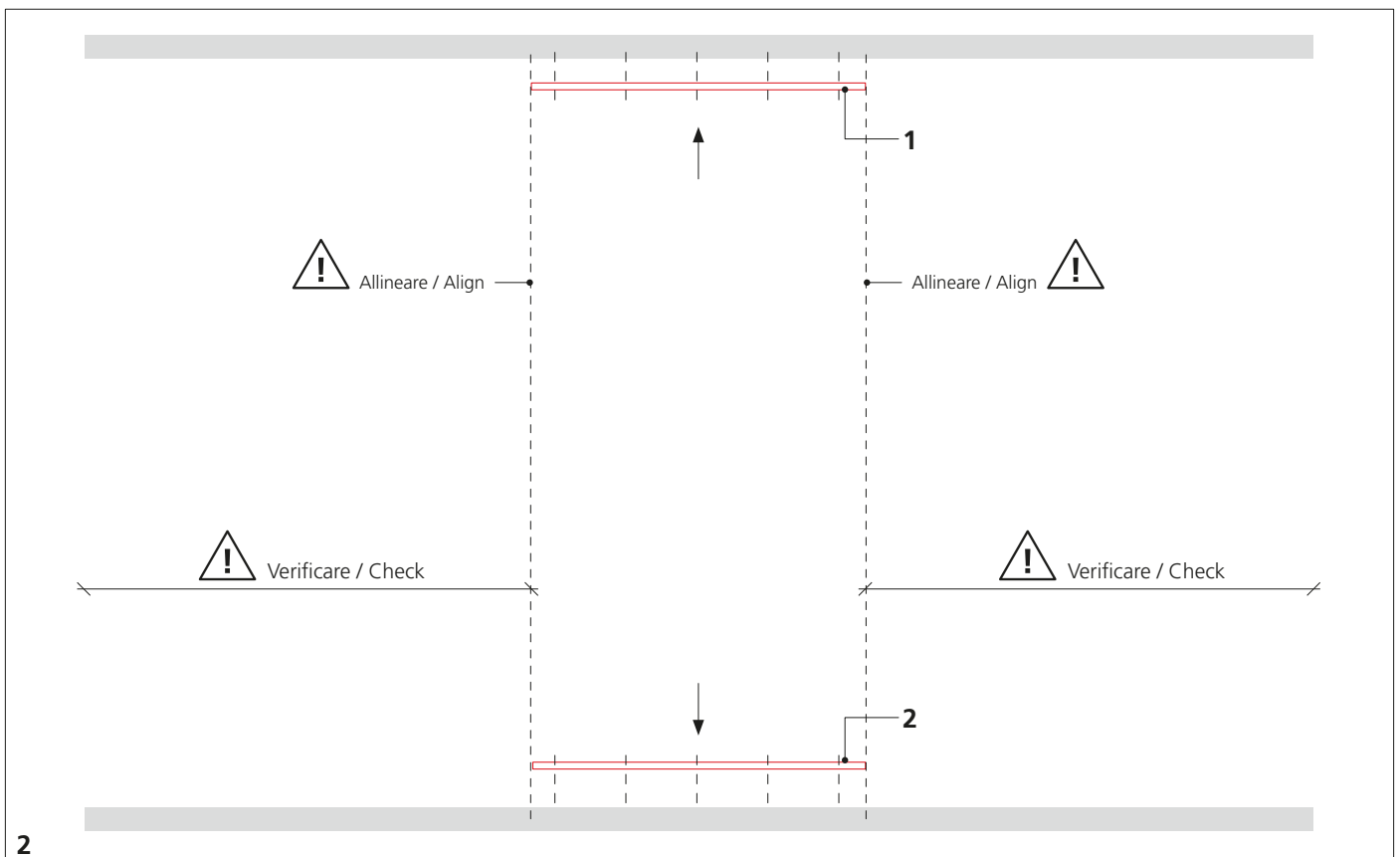

2. Fissare il profilo a soffitto ed il profilo a pavimento. Verificare le distanze laterali per l'inserimento delle ante.  
2. Fix the profile to the floor and to the ceiling. Check the lateral distance to insert the doors.

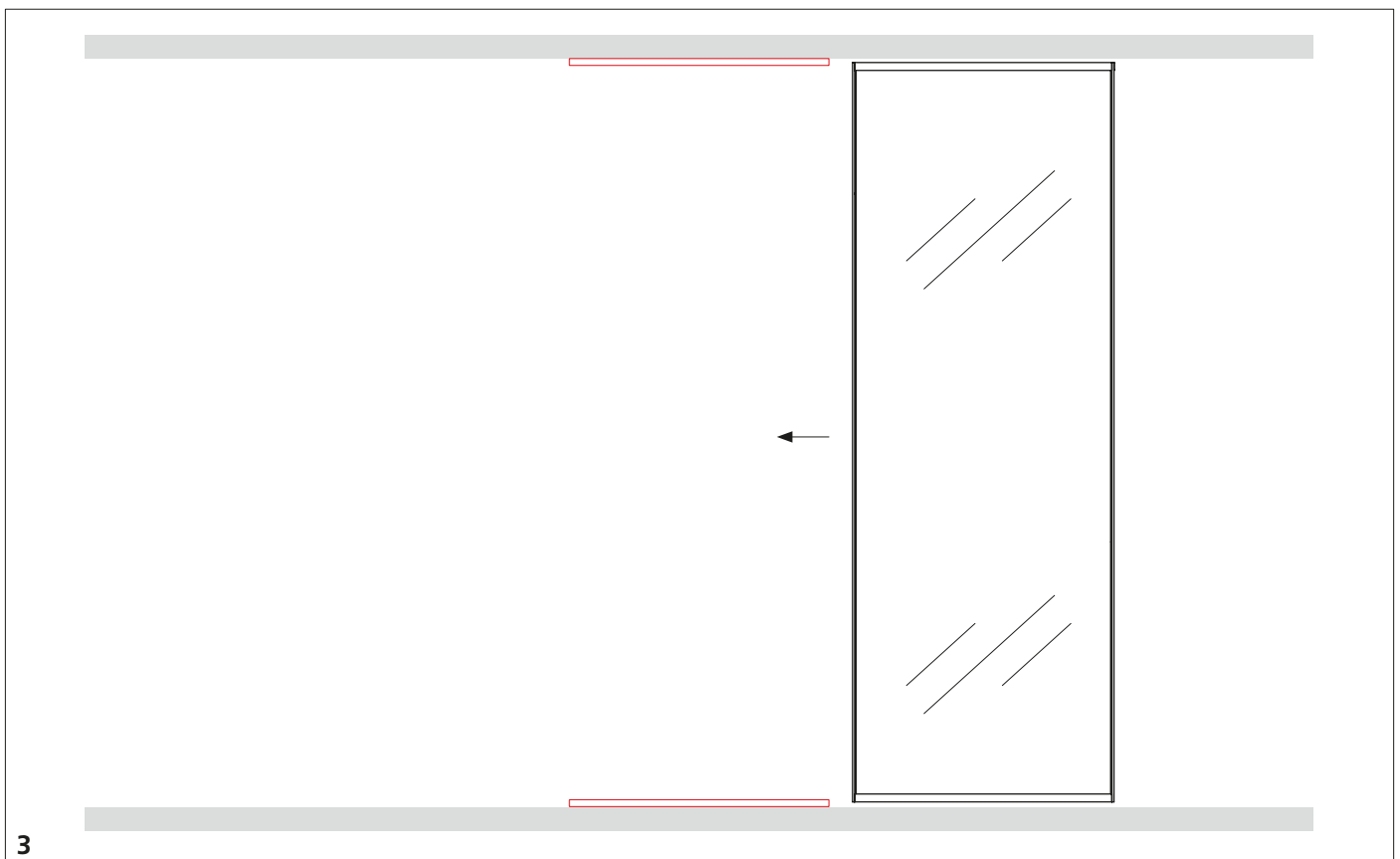
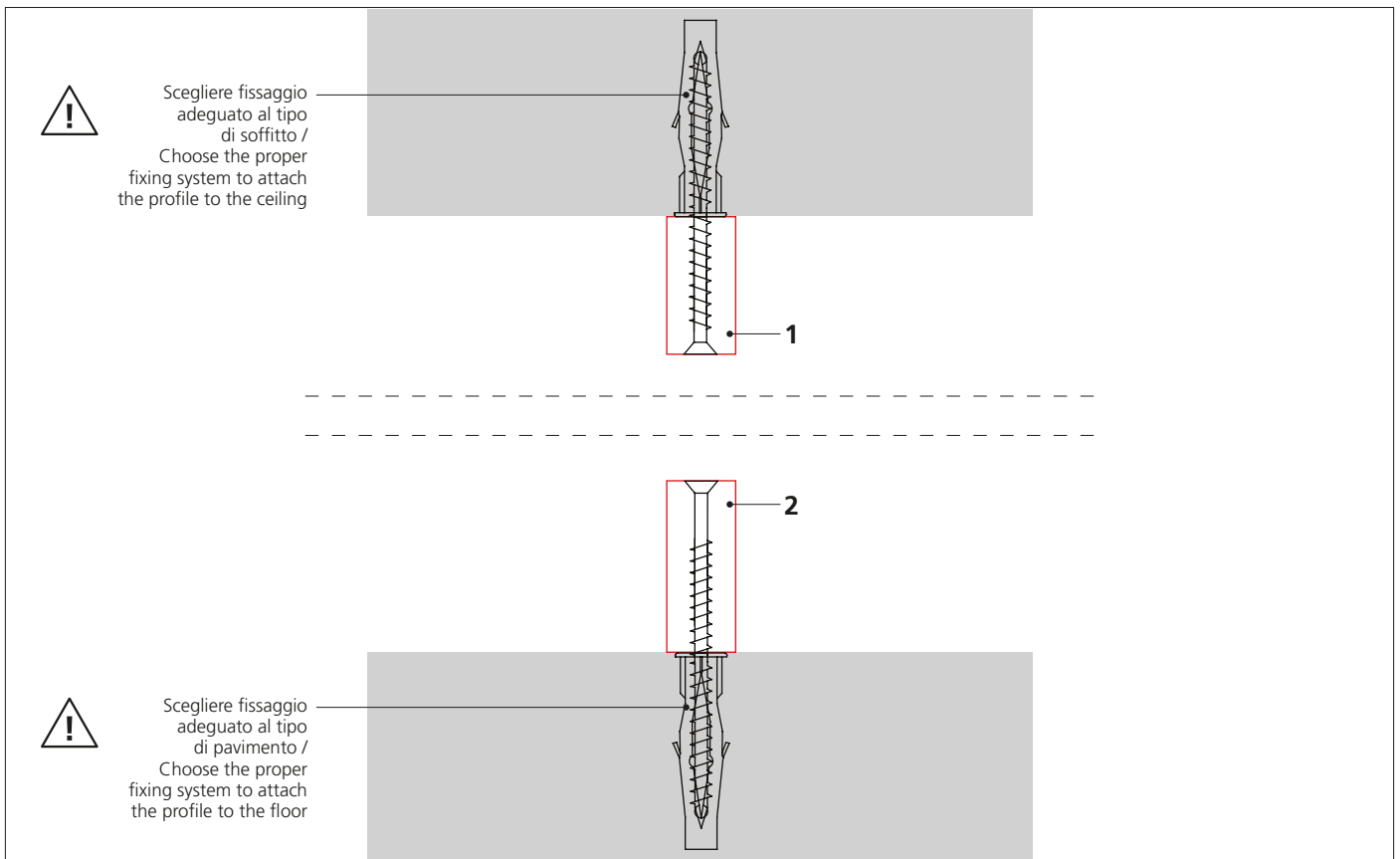

**3. Infilare l'anta nei profili.**  
**3. Let the door slip into the profiles.**



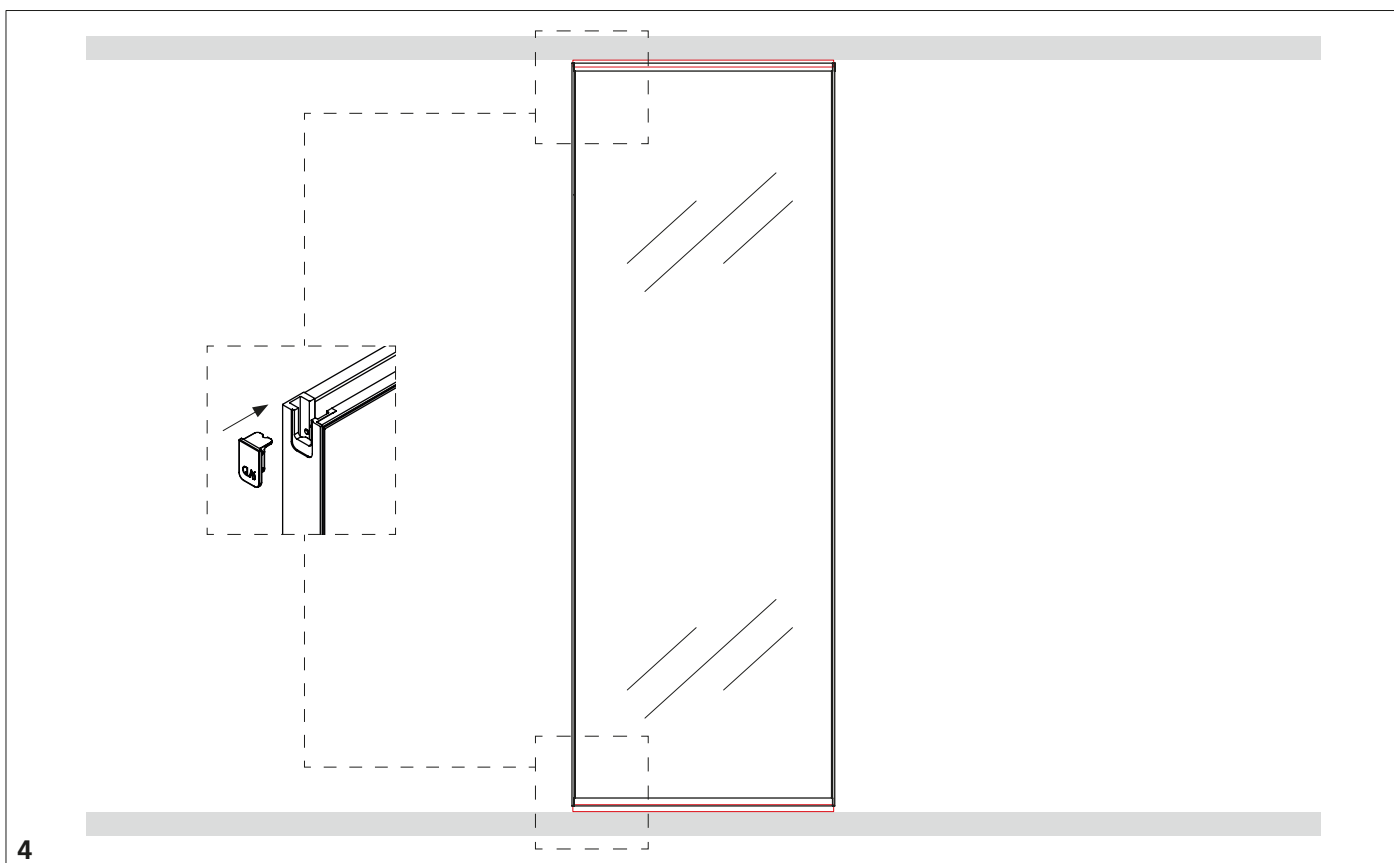

4. Chiudere lateralmente l'anta con i tappi in dotazione.  
4. Close the side opening with the includes caps.

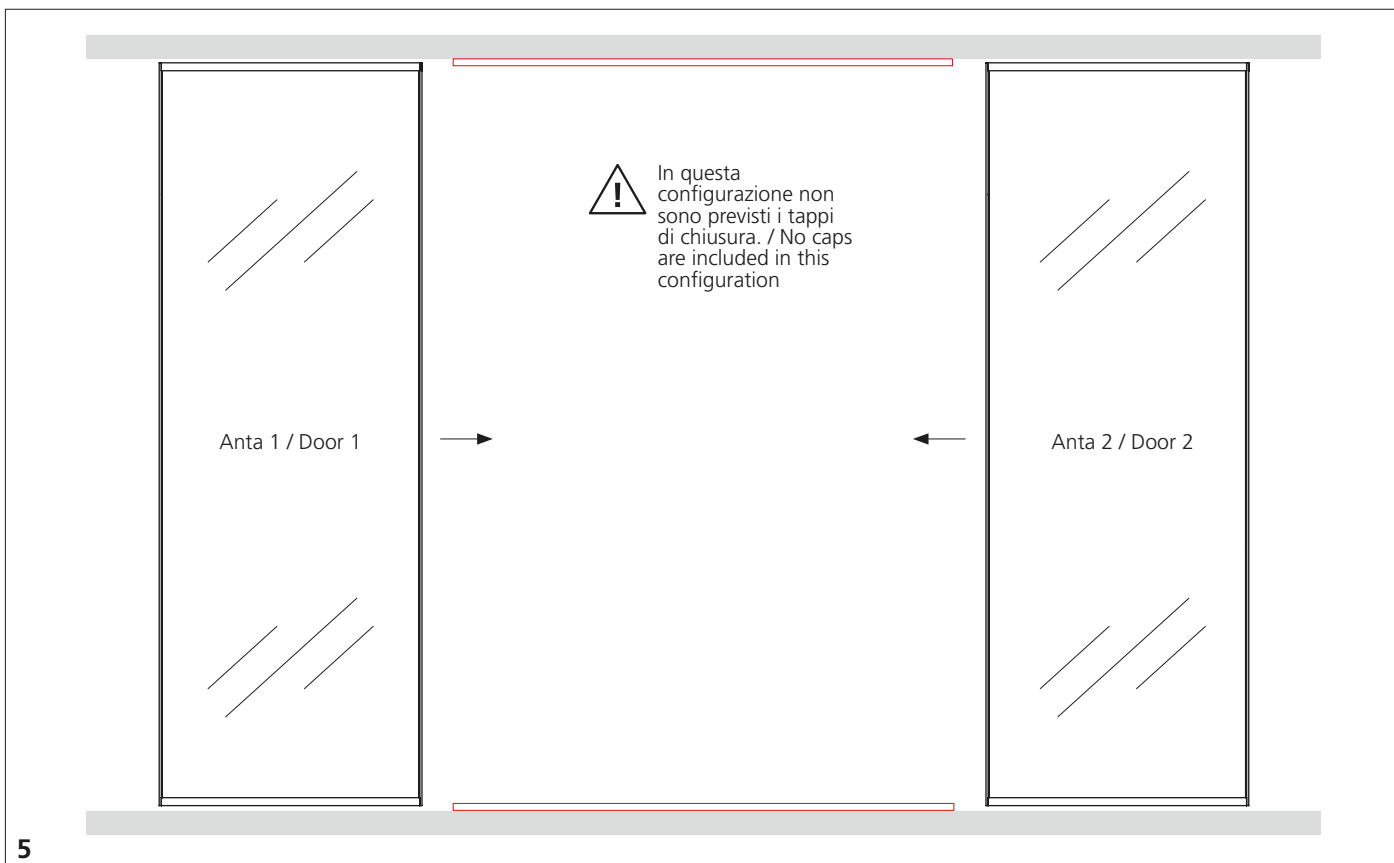

5. In caso di composizione con più ante, seguire la numerazione delle ante presente sui disegni di progetto.  
5. In case of composition with several doors, follow the numbering of the doors on the design drawings.

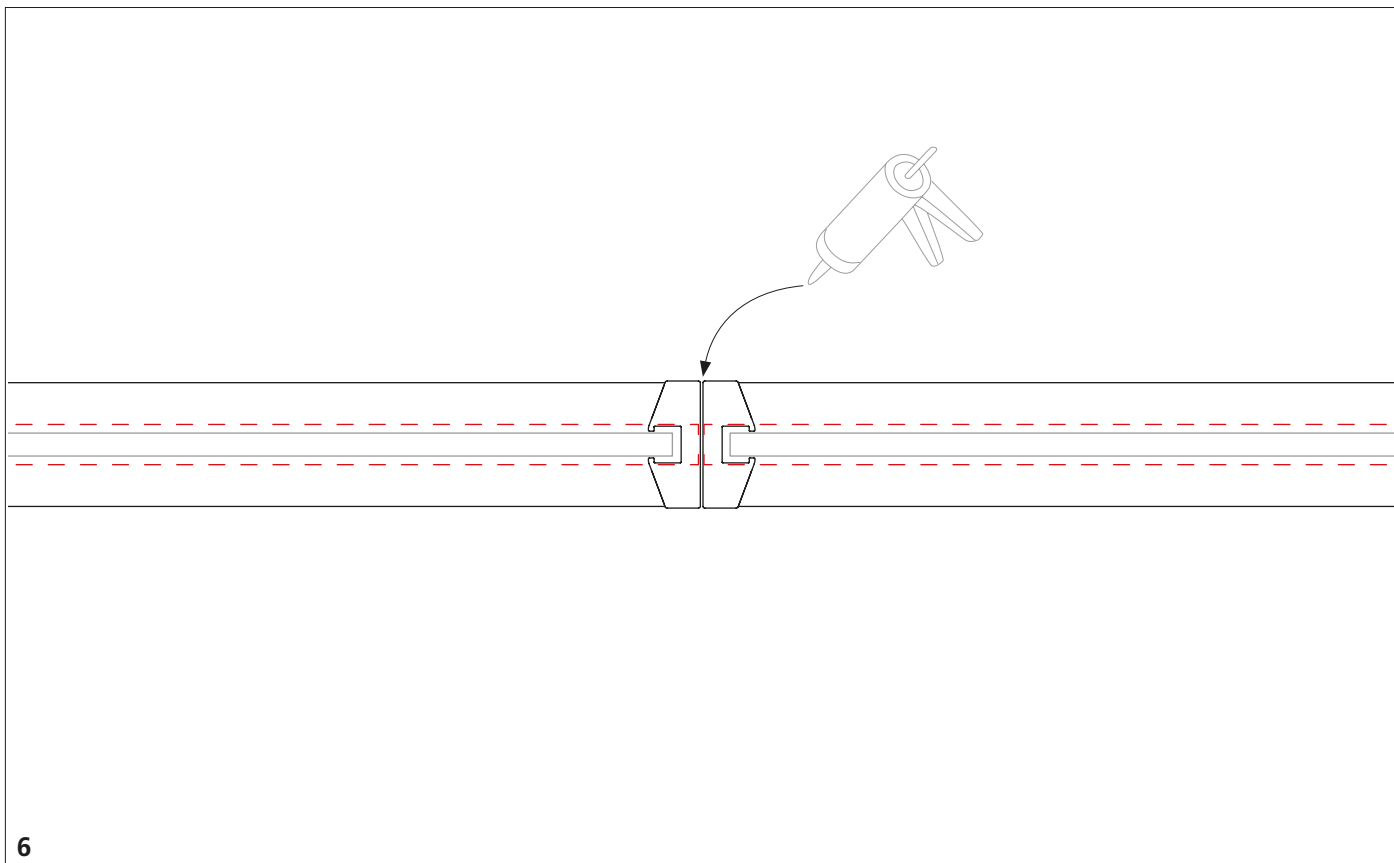

6. Fissare le ante con silicone neutro.  
6. Fix the doors with neutral silicone.